

I MICRO-FICHE VESPA "SFERA 50 - SFERA 80", AUSGABE 07/94

I MODELLBEZEICHNUNG:

	MODELL-NR.:	VORZ.:	FG.-NR.:
I VESPA - SFERA 50 : KLEINKRAFTROLLER BIS 50 CCM, MIT STUFENLOSEM I AUTOMATIKGETRIEBE UND GETRENNTSCHMIERUNG I ELEKTRO- U. KICKSTARTER, 4-FACH BLINKLICHT- I ANLAGE, FERN- UND ABLENDLICHT SOWIE STOPP- I LICHT. AUSSERDEM VERFUEGT DER ROLLER IBER I EIN ABSCHLIESSBARES GEPAECKFACH, EIN SEPARATES I HELMFACH UNTER DER SITZBANK, HUPE, ALURAEUER I MIT 3 STEGEN, VORDERRADSCHINGENFEDERUNG UND I MONOSTOSSDAEMPFER HINTEN SOWIE EINE QUARZUHR. I MODELL OHNE KAT	550	NSLIT.....	
I VESPA - SFERA 50 MAQUILLAGE : BESCHREIB. WIE MOD. 550, OHNE KAT	552	NSLIT.....	AB APRIL 94
I VESPA - SFERA 50 : BESCHREIBUNG WIE MODELL 550, JEDOCH MIT KAT	551	NSLIT.....	
I VESPA - SFERA 50 MAQUILLAGE : BESCHREIB. WIE MOD. 551, MIT KAT	553,	NSLIT.....	AB APRIL 94
I VESPA - SFERA 80 : LEICHTKRAFTROLLER BIS 80 CCM, ANSONSTEN I BESCHREIBUNG WIE MODELL 550, OHNE KAT	555	NS81T.....	
I VESPA - SFERA 80 MAQUILLAGE : BESCHREIB. WIE MOD. 555, OHNE KAT	557	NS81T.....	AB APRIL 94
I VESPA - SFERA 80 : BESCHREIB. WIE MOD. 555, MIT KAT	556	NS81T.....	
I VESPA - SFERA 80 MAQUILLAGE : BESCHREIB. WIE MOD. 555, MIT KAT	558	NS81T.....	AB APRIL 94

I DER MICRO-FICHE VESPA "SFERA 50 - SFERA 80", AUSGABE 7/93
I IST NICHT MEHR GUELTIG.

I			I
I			I
I			I
I	MODELLBEZEICHNUNG - KENNZIFFERSCHLUESSEL	SPALTE A 1	I
I	INHALTSVERZEICHNIS	SPALTE B 1 - C 1	I
I	ALPHABETISCHES INHALTSVERZEICHNIS	SPALTE D 1 - G 1	I
I			I
I			I
I	INHALTSVERZEICHNIS		I
I	=====		I
I			I
I	MOTOR	SPALTE A 2 TAFEL 01	I
I			I
I	KURBELGEHAEUSE	SPALTE B 2 TAFEL 02	I
I			I
I	KURBELWELLE	SPALTE C 2 TAFEL 03	I
I			I
I	GRUPPE ZYLINDER - KOLBEN - KOLBENBOLZEN	SPALTE D 2 TAFEL 04	I
I			I
I	ZYLINDERKOPF - KUEHLHAUBE - EINLASSTUTZEN	SPALTE E 2 TAFEL 05	I
I			I
I	KUPPLUNGSDECKEL - LUEFTERGEHAEUSEDECKEL	SPALTE A 3 TAFEL 06	I
I			I
I	GETRIEBENE RIEMENSCHLEIBE	SPALTE B 3 - C 3 TAFEL 07	I
I			I
I	TREIBENDE RIEMENSCHLEIBE	SPALTE D 3 - E 3 TAFEL 08	I
I			I
I	HINTERRADACHSE	SPALTE F 3 - G 3 TAFEL 09	I
I			I
I	LICHTMASCHINE	SPALTE H 3 TAFEL 10	I
I			I
I	ANLASSERMOTOR - KICKSTARTER	SPALTE I 3 - J 3 TAFEL 11	I
I			I
I	OELPUMPE	SPALTE K 3 TAFEL 12	I
I			I
I	BREMSHEBEL FUER HINTERRAD	SPALTE L 3 TAFEL 13	I
I			I
I	VERGASER	SPALTE A 4 TAFEL 14	I
I			I
I	VERGASER - BESTANDTEILE	SPALTE B 4 - C 4 TAFEL 15	I
I			I
I	LUFTFILTER	SPALTE D 4 TAFEL 16	I
I			I
I	SCHALLDAEMPFER	SPALTE E 4 - F 4 TAFEL 17	I
I			I
I	FAHRGESTELL - MOTORAUFNAHME	SPALTE A 5 - B 5 TAFEL 18	I
I			I
I	FRONT-VERKLEIDUNGSELEMENTE	SPALTE C 5 TAFEL 19	I
I			I
I	GEPAECKFACH	SPALTE D 5 - E 5 TAFEL 20	I
I			I
I	OELTANK	SPALTE A 6 TAFEL 21	I
I			I
I	BENZINTANK	SPALTE B 6 - C 6 TAFEL 22	I
I			I
I	HELMFACH	SPALTE D 6 TAFEL 23	I

I ALPHABETISCHES INHALTSVERZEICHNIS			I	I
I =====			I	I
I ABZIEHBILDERSATZ IN FARBE TUERKIS	SPALTE C 7	TAFEL 24	I	I
I ABSCHMELZSICHERUNG	SPALTE E 12	TAFEL 41	I	I
I ANKERPLATTE (LICHTMASCHINE)	SPALTE H 3	TAFEL 10	I	I
I ANLASSERMOTOR	SPALTE I 3	TAFEL 11	I	I
I ANLASSERRITZEL	SPALTE E 3	TAFEL 08	I	I
I ANLASSERSCHALTER AM LENKER	SPALTE E 12	TAFEL 40	I	I
I ANSCHLUSSTUTZEN FUER OELTANK	SPALTE A 6	TAFEL 21	I	I
I ANTRIEBSWELLE	SPALTE F 3	TAFEL 09	I	I
I AUSPUFFBLENDE	SPALTE E 4	TAFEL 17	I	I
I AUSPUFFTOPF	SPALTE E 4	TAFEL 17	I	I
I BATTERIE	SPALTE F 12	TAFEL 41	I	I
I BEIFAHRERHALTEGRIF - SATZ	SPALTE D 7	TAFEL 26	I	I
I BENZINHAHN	SPALTE B 6	TAFEL 22	I	I
I BENZINSCHLAUCH	SPALTE B 6	TAFEL 22	I	I
I BENZINSTANDSANZEIGER	SPALTE B 6	TAFEL 22	I	I
I BENZINTANK	SPALTE B 6	TAFEL 22	I	I
I BENZINTANKVERSCHLUSS	SPALTE B 6	TAFEL 22	I	I
I BLINKGEBER	SPALTE F 12	TAFEL 41	I	I
I BLINKLEUCHTEN - VORN	SPALTE B 12	TAFEL 38	I	I
I BLINKLEUCHTEN - HINTEN : SIEHE RUECKLEUCHE!	SPALTE C 12	TAFEL 39	I	I
I BLINKLICHTSCHALTER	SPALTE E 12	TAFEL 40	I	I
I BREMSANKERPLATTE FUER VORDERRAD	SPALTE B 8	TAFEL 28	I	I
I BREMSBACKEN FUER HINTERRAD	SPALTE L 3	TAFEL 13	I	I
I BREMSBACKEN FUER VORDERRAD	SPALTE D 8	TAFEL 29	I	I
I BREMSBACKENSCHUH FUER HINTERRAD	SPALTE L 3	TAFEL 13	I	I
I BREMSBACKENSCHUH FUER VORDERRAD	SPALTE C 8	TAFEL 29	I	I
I BREMSEINSTELLSCHRAUBEN	SPALTE B 11	TAFEL 36	I	I
I BREMSHEBEL AM HINTERRAD	SPALTE L 3	TAFEL 13	I	I
I BREMSHEBEL AM VORDERRAD	SPALTE C 8	TAFEL 29	I	I
I BREMSHEBEL - FUER HINTERRAD - AM LENKER	SPALTE D 10	TAFEL 34	I	I
I BREMSHEBEL - FUER VORDERRAD - AM LENKER	SPALTE C 10	TAFEL 33	I	I
I BREMSLICHTSCHALTER - FUER HINTERRAD - AM LENKER	SPALTE D 10	TAFEL 34	I	I
I BREMSLICHTSCHALTER - FUER VORDERRAD - AM LENKER	SPALTE C 10	TAFEL 33	I	I
I BREMSZUG FUER HINTER- UND VORDERRAD	SPALTE B 11	TAFEL 36	I	I
I DECKEL FUER ANTRIEBSWELLE	SPALTE F 3	TAFEL 09	I	I
I DICHRINGSATZ FUER MOTOR	SPALTE A 2	TAFEL 01	I	I
I DICHTUNGSSATZ FUER MOTOR	SPALTE A 2	TAFEL 01	I	I
I DICHTUNGSSATZ FUER VERGASER	SPALTE A 4	TAFEL 14	I	I
I DUESENNADEL	SPALTE C 4	TAFEL 15	I	I
I EINLASSMEMBRANE	SPALTE E 2	TAFEL 05	I	I
I EINLASSTUTZEN	SPALTE E 2	TAFEL 05	I	I
I ELEKTRONIKZENTRALE	SPALTE A 12	TAFEL 37	I	I
I ENTLUEFTUNGSSCHLAUCH FUER BENZINTANK	SPALTE B 6	TAFEL 22	I	I
I FAHRGESTELL	SPALTE A 5	TAFEL 18	I	I
I FERNSCHALTER FUER ANLASSER	SPALTE F 12	TAFEL 41	I	I
I FUSSRAUMABDECKUNG	SPALTE D 5	TAFEL 20	I	I

I GASDREHGRIF	SPALTE C 10	TAFEL 33	I	I
---------------	-------------	----------	---	---

I				I
I				I
I	GASDREHGRIFF	SPALTE C 10	TAFEL 33	I
I	GASSCHIEBER	SPALTE B 4	TAFEL 15	I
I	GASSCHIEBERDECKEL	SPALTE B 4	TAFEL 15	I
I	GASZUG	SPALTE A 11	TAFEL 35	I
I	GEPAECKFACHEINHEIT	SPALTE D 5	TAFEL 20	I
I	GEPAECKFACHRIEGEL	SPALTE D 5	TAFEL 20	I
I	GEPAECKKHAKEN	SPALTE B 7	TAFEL 24	I
I				I
I	HALTER FUER KENNZEICHENLEUCHTE	SPALTE C 12	TAFEL 39	I
I	HAUPTDUESE	SPALTE L 3	TAFEL 15	I
I	HECKVERKLEIDUNG MIT AUFNAHME FUER LEUCHTENEINSATZ	SPALTE C 12	TAFEL 39	I
I	HELMFACH	SPALTE D 6	TAFEL 23	I
I	HINTERRADACHSE	SPALTE F 3	TAFEL 09	I
I	HINTERRADFELGE	SPALTE A 13	TAFEL 42	I
I	HUPE	SPALTE E 12	TAFEL 40	I
I	HUPENSCHALTER	SPALTE E 12	TAFEL 40	I
I				I
I	KABELLAST FUER BATTERIE	SPALTE F 12	TAFEL 41	I
I	KABELLAST FUER SCHEINWERFER UND BLINKLEUCHTEN	SPALTE B 12	TAFEL 38	I
I	KABELBAUM	SPALTE A 12	TAFEL 37	I
I	KALTSTARTVORRICHTUNG	SPALTE B 4	TAFEL 15	I
I	KEILRIEMEN FUER AUTOMATIKKUPPLUNG	SPALTE D 3	TAFEL 08	I
I	KEILRIEMEN FUER OELPUMPE	SPALTE K 3	TAFEL 12	I
I	KENNZEICHENTRAEGER	SPALTE C 12	TAFEL 39	I
I	KICKSTARTERHEBEL	SPALTE I 3	TAFEL 11	I
I	KICKSTARTERSEGMENT	SPALTE I 3	TAFEL 11	I
I	KIPPSTAENDER	SPALTE A 5	TAFEL 18	I
I	KNOPFBATTERIE FUER QUARZUHR IM TACHOMETER	SPALTE A 10	TAFEL 32	I
I	KOLBEN	SPALTE D 2	TAFEL 04	I
I	KOLBENBOLZEN	SPALTE D 2	TAFEL 04	I
I	KOLBENRING	SPALTE D 2	TAFEL 04	I
I	KOTFLUEGEL - HINTERRAD	SPALTE D 7	TAFEL 25	I
I	KOTFLUEGEL - VORDERRAD	SPALTE D 7	TAFEL 25	I
I	KRUEMMER	SPALTE E 4	TAFEL 17	I
I	KUEHLHAUBE	SPALTE E 2	TAFEL 05	I
I	KUPPLUNGSDECKEL	SPALTE A 3	TAFEL 06	I
I	KUPPLUNGSGLOCKE	SPALTE B 3 - C 3	TAFEL 07	I
I	KUPPLUNGSTROMMEL	SPALTE C 3	TAFEL 07	I
I	KURBELGEHAEUSE	SPALTE B 2	TAFEL 02	I
I	KURBELWELLE	SPALTE C 2	TAFEL 03	I
I				I
I	LEERLAUFDUESE	SPALTE B 4	TAFEL 15	I
I	LEERLAUFEINSTELLSCHRAUBE	SPALTE B 4	TAFEL 15	I
I	LENKER	SPALTE D 10	TAFEL 34	I
I	LENKERDECKELHAELFTEN	SPALTE A 10	TAFEL 32	I
I	LICHTMASCHINE	SPALTE H 3	TAFEL 10	I
I	LICHTSCHALTER	SPALTE E 12	TAFEL 40	I
I	LICHTUMSCHALTER FUER FERN- UND ABBLENDLICHT	SPALTE E 12	TAFEL 40	I
I	LUEFTERGEHAEUSEDECKEL	SPALTE A 3	TAFEL 06	I
I	LUEFTERRAD	SPALTE H 3	TAFEL 10	I
I	LUFTFILTER	SPALTE D 4	TAFEL 16	I
I	LUFTFILTERELEMENT	SPALTE D 4	TAFEL 16	I
I	LUFTREGULIERSCHRAUBE (VERGASER)	SPALTE C 4	TAFEL 15	I
I	LUFTVENTIL AM RAD	SPALTE A 13	TAFEL 42	I
I				I
I				I
I				I

I				I
I				I
I	MISCHERROHR (VERGASER)	SPALTE B 4	TAFEL 15	I

I				I
I				I
I	MISCHERROHR (VERGASER)			I
I	MOTOR	SPALTE B 4	TAFEL 15	I
I	MOTORAUFNAHME	SPALTE A 2	TAFEL 01	I
I		SPALTE A 5	TAFEL 18	I
I				I
I	OELPUMPE	SPALTE K 3	TAFEL 12	I
I	OELPUMPENZUG	SPALTE A 11	TAFEL 35	I
I	OELSTANDSANZEIGER	SPALTE A 6	TAFEL 21	I
I	OELTANK	SPALTE A 6	TAFEL 21	I
I	OELTANKVERSCHLUSS	SPALTE A 6	TAFEL 21	I
I				I
I	PICK UP - (LICHTMASCHINE)	SPALTE H 3	TAFEL 10	I
I	PLAKETTE (PIAGGIO-EMBLEM)	SPALTE B 5	TAFEL 19	I
I	PLAKETTE "SFERA"	SPALTE D 5	TAFEL 20	I
I	PLAKETTE "SFERA"	SPALTE A 7	TAFEL 24	I
I	PLAKETTE "S 50"	SPALTE A 7	TAFEL 24	I
I	PLEUELSTANGE	SPALTE C 2	TAFEL 03	I
I				I
I	REGELSCHNEIBENHAELFTE	SPALTE B 3	TAFEL 07	I
I	REGLER - ELEKTRONISCH	SPALTE A 12	TAFEL 37	I
I	REGLERGEHAEUSEHAELFTE	SPALTE D 3	TAFEL 08	I
I	REIFEN	SPALTE A 13	TAFEL 42	I
I	RIEMENSCHNEIBE FUER OELPUMPE	SPALTE D 3	TAFEL 08	I
I	RIEMENSCHNEIBENHAELFTE - GETRIEBEN	SPALTE B 3 + C 3	TAFEL 07	I
I	RIEMENSCHNEIBENHAELFTE - TREIBEND	SPALTE D 3	TAFEL 08	I
I	ROTOR (LICHTMASCHINE)	SPALTE H 3	TAFEL 10	I
I	RUECKLEUCHTE- / BLINKLEUCHTENEINSATZ	SPALTE C 12	TAFEL 39	I
I				I
I	SCHALLDAEMPFER	SPALTE E 4	TAFEL 17	I
I	SCHNITTWERFER	SPALTE B 12	TAFEL 38	I
I	SCHNITTWERFERVERKLEIDUNGSTEIL	SPALTE C 5	TAFEL 19	I
I	SCHNITTWERFERVERSCHLUSSKAPPE	SPALTE B 12	TAFEL 38	I
I	SCHLOSSKOERPER	SPALTE E 12	TAFEL 40	I
I	SCHLOSSSATZ	SPALTE E 12	TAFEL 40	I
I	SCHLUESSEL	SPALTE E 12	TAFEL 40	I
I	SCHWIMMER	SPALTE B 4	TAFEL 15	I
I	SCHWIMMERGEHAEUSE	SPALTE B 4	TAFEL 15	I
I	SCHWIMMERNADEL	SPALTE B 4	TAFEL 15	I
I	SEITENVERKLEIDUNGSELEMENTE	SPALTE A 7 - B 7	TAFEL 24	I
I	SICHERUNGSHALTER	SPALTE F 12	TAFEL 41	I
I	SITZBANK	SPALTE F 7	TAFEL 26	I
I	SITZBANKRIEGEL	SPALTE A 7	TAFEL 24	I
I	SITZBANKSCHLOSS - SIEHE SCHLOSSSATZ	SPALTE B 7	TAFEL 24	I
I	SITZBANKUNTERTEIL	SPALTE A 7 - B 7	TAFEL 24	I
I	SITZBANKVERSCHLUSS	SPALTE F 7	TAFEL 26	I
I	SPEZIALFETT FUER GETRIEBENE RIEMENSCHNEIBE	SPALTE C 3	TAFEL 07	I
I	SPEZIALWERKZEUG	SPALTE A 14	TAFEL 43	I
I	STARTERWELLE	SPALTE F 3	TAFEL 09	I
I	STEBOLZEN	SPALTE B 2	TAFEL 02	I
I	STEUERROHR	SPALTE C 8	TAFEL 28	I
I	STEUERROHRLAGER	SPALTE A 8	TAFEL 27	I
I	STEUERROHRSCHUTZ	SPALTE C 5	TAFEL 19	I
I				I
I				I
I				I
I				I
I				I
I				I
I				I
I				I

I				I
I				I
I	STEUERROHRSCHUTZANSCHLUSSSTEIL	SPALTE C 5	TAFEL 19	I

I TAFEL 01 MOTOR SPALTE 2A I ABB. BENENNUNG I ERSATZTEIL I ST IKENNZIFFER I BEMERKUNGEN I

ABB. BENENNUNG	ERSATZTEIL	ST IKENNZIFFER	BEMERKUNGEN
1 MOTOR KPL.	289378	1 1550,	IA: MIT TEILEN
A			DER TAFELN
1 MOTOR KPL.	434264	1 1552,	2 BIS 15.
ABI			
1 MOTOR KPL. (KAT)	432466	1 1551,	
A			
1 MOTOR KPL. (KAT)	434271	1 1553,	18: AB APRIL 94
ABI			
1 MOTOR KPL.	434023	1 1555,	
A			
1 MOTOR KPL.	434282	1 1557,	
ABI			
1 MOTOR KPL. (KAT)	432755	1 1556,	
A			
1 MOTOR KPL. (KAT)	434281	1 1558,	
ABI			
2 MOTORDICHTUNGS- SATZ	154873	1 1550,551,555, 1552,553,557	
		1556,558,	
3 MOTORDICHTRING- SATZ	498337	1 1550,551,555, 1552,553,557 1556,558,	

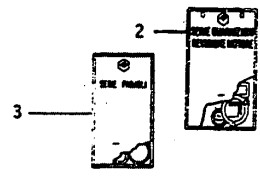
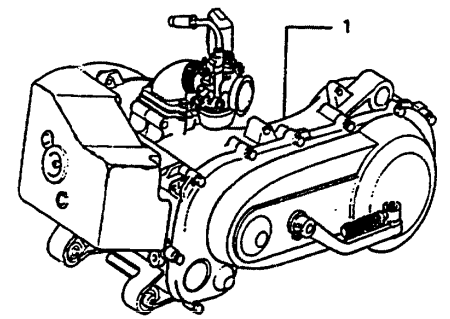

L 94

L 94

94

94

I TAFEL 02 KURBELGEHAUSE SPALTE 2B I ABB. BENENNUNG I ERSATZTEIL I ST IKENNZIFFER I BEMERKUNGEN I ITA

L 01
L 02
L 03
L 04
L 05
L 06
L 07
L 08
L 09
L 10
L 11
L 12
L 13
L 14
L 15
L 16
L 17
L 18
L 19
L 20
L 21
L 22
L 23

TAFEL 02	KURBELGEHAEUSE	SPALTE 2B	I ABB. BENENNUNG	I ERSATZTEIL	I ST IKENNZIFFER	I BEMERKUNGEN
			1 KURBELGEHAEUSE KPI	430320	1 1550,551,552, 1553,	IA: MIT ABB. 2-8
			1 KURBELGEHAEUSE KPI	430342	1 1555,556,557, 1558,	
			2 STEHBOLZEN	239382	4 1550,551,552, 1553,	
			2 STEHBOLZEN	288391	4 1555,556,557, 1558,	
			3 MUTTER	020006	1 1550,551,555, 1552,553,557	
			4 SPRENGRING	287223	1 1550,551,555, 1552,553,557	
			5 SPRENGRING	113533	2 1550,551,555, 1552,553,557	
			6 MUTTER	020008	2 1550,551,555, 1552,553,557	
			7 PUFFER	267823	1 1550,551,555, 1552,553,557	
			8 DISTANZSTUECK	266625	1 1550,551,555, 1552,553,557	

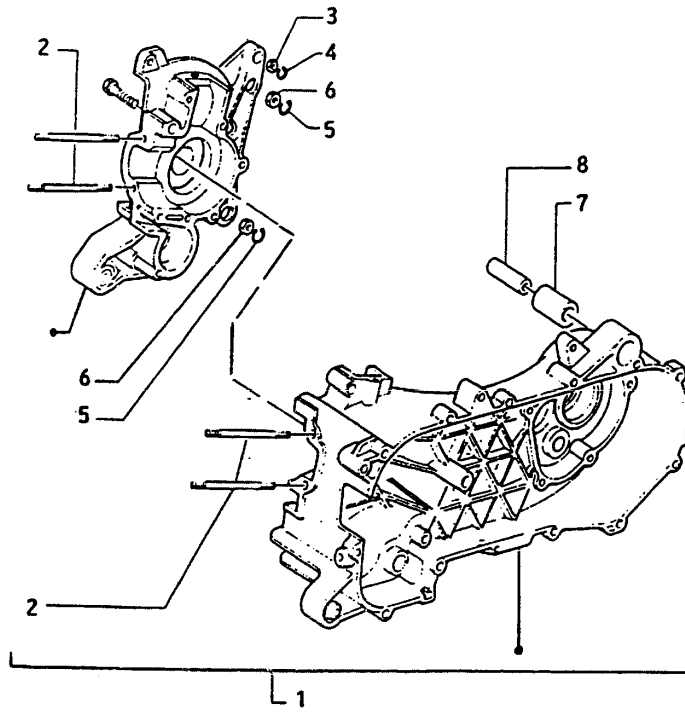

TAFEL 03	KURBELWELLE	SPALTE 2C	I ABB. BENENNUNG	I ERSATZTEIL	I ST IKENNZIFFER	I BEMERKUNGEN
----------	-------------	-----------	------------------	--------------	------------------	---------------

I TAFEL 03 KURBELWELLE

SPALTE 2C

I ABB. BENENNUNG I ERSATZTEIL I ST IKENNZIFFER I BEMERKUNGEN I

- 24
- 25
- 26
- 27
- 28
- 29
- 30
- 31
- 32
- 33
- 34
- 35
- 36
- 37
- 38
- 39
- 40
- 41
- 42
- 43



ABB. BENENNUNG	ERSATZTEIL	ST IKENNZIFFER	BEMERKUNGEN
1 LAGER	431125	2 I550,551,555, I552,553,557 I556,558.	
2 DICHRING	286359	1 I550,551,555, I552,553,557 I556,558.	
3 NADELKAEFIG	112145	1 I550,551,555, A I552,553,557 I556,558.	IA: IN DEN KATE- GORIEN 1,2,3 ODER 4 BEST.
4 PLEUELSTANGE KPL.	289000	1 I550,551,552, B I553.	
4 PLEUELSTANGE KPL.	289706	1 I555,556,557, B I558.	
5 KURBELWELLE KPL.	286912	1 I550,551,552, C I553.	
5 KURBELWELLE KPL.	289322	1 I555,556,557, C I558.	IB: MIT ABB. 3
6 DICHRING	239391	1 I550,551,555, I552,553,557 I556,558.	IC: MIT ABB. 4

I TAFEL 04 GRUPPE ZYLINDER- KOLBEN- K.BOLZEN SPALTE 2D

I ABB. BENENNUNG I ERSATZTEIL I ST IKENNZIFFER I BEMERKUNGEN I

I I TAFEL

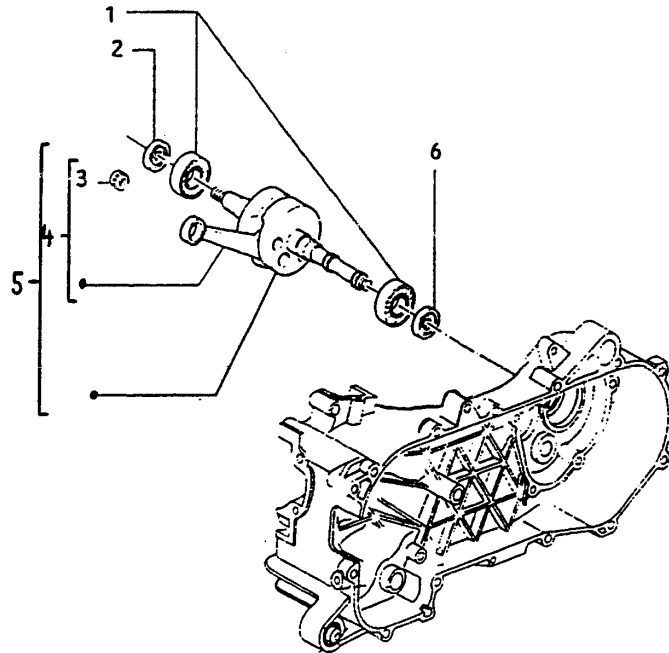
24
41
10
11
08
40
21
09
17
17

41
26
22
22
22
41
38
39
40
28
13
29
13
29
36
13
29
34
33
34
33
36

09
01
01
14
15

05
05
37
22

18
41
20

TAFEL 04 GRUPPE ZYLINDER- KOLBEN- K.BOLZEN SPALTE 2D



ABB. BENENNUNG	ERSATZTEIL	ST	IKENNZIFFER	IBEMERKUNGEN
1 DICHTUNG	288910	1	1550,551,555, 1552,553,557, 1556,558,	
1 DICHTUNG 0,2 MM	434291	1	1556,558,	ID: AB MOTOR-NR.: NS81M 81067
1 DICHTUNG 0,3 MM	434292	1	1556,558,	
1 DICHTUNG 0,4 MM	434293	1	1556,558,	
1 DICHTUNG 0,5 MM	434294	1	1556,558,	
1 DICHTUNG 0,6 MM	434295	1	1556,558,	
1 DICHTUNG 0,7 MM	434296	1	1556,558,	
1 DICHTUNG 0,8 MM	434297	1	1556,558,	
2 KOLBENBOLZEN	239404	1	1550,551,552, 1553,	
2 KOLBENBOLZEN	288396	1	1555,556,557, 1558,	
3 SPRENGRING	239455	2	1550,551,555, 1552,553,557, 1556,558,	
4 KOLBENRING	239403	2	1550,551,552, 1553,	
4 KOLBENRING	289355	2	1555,556,557, 1558,	
5 STIFTSCHRAUBE	239397	2	1550,551,555, 1552,553,557, 1556,558,	
6 GRUPPE KOLBEN / KOLBENBOLZEN NORMALMASS	288990	1	1550,551,552, 1553,	IA: MIT ABB. 2-4
6 GRUPPE KOLBEN / KOLBENBOLZEN	289705	1	1555,556,557, 1558,	IB: IN DEN KATE- 1,2,3 OD. 4 BESTELLEN.
6 GRUPPE KOLBEN / KOLBENBOLZEN 1. UEBERMASS	288991	1	1550,551,552, 1553,	
6 GRUPPE KOLBEN / KOLBENBOLZEN 2. UEBERMASS	288992	1	1550,551,552, 1553,	
7 GRUPPE ZYLINDER / KOLBEN / KOLBEN- BOLZEN	288989	1	1550,551,552, 1553,	IC: MIT ABB. 5+6
7 GRUPPE ZYLINDER / KOLBEN / KOLBEN- BOLZEN	289704	1	1555,556,557, 1558,	

TAFEL 05 ZYL.KOPF / K.HAUBE / EINL.STUTZEN SPALTE 2E

ABB. BENENNUNG	ERSATZTEIL	ST	IKENNZIFFER	IBEMERKUNGEN
----------------	------------	----	-------------	--------------

22

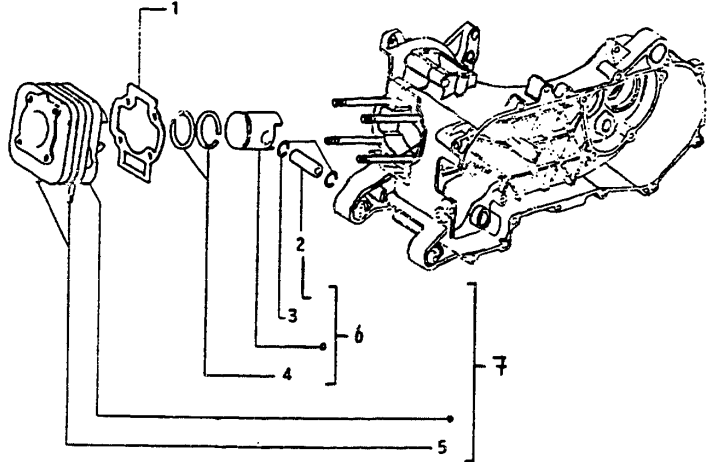
TAFEL

TAFEL

33
15
15
35
20
20
24

39
15
39
23
09
42
40
40

+1
38
37
15
08
12
39
11
11
18
32
04
04
05
17
05
16
17
12
13

5
5
14
00
00
00
06
06
06
05
2

TAFEL 05 ZYL.KOPF / K.HAUBE / EINL.STUTZEN SPALTE 2E



ABB. BENENNUNG	ERSATZTEIL	ST	IKENNZIFFER	IBEMERKUNGEN
1 KUEHLHAUBE	286936	1	1550,551,552, 1553,	
1 KUEHLHAUBE	431536	1	1550,551,552, 1553,	IA: AB MAI 93
1 KUEHLHAUBE	288410	1	1555,556,	
1 KUEHLHAUBE	433926	1	1555,556,557, 1558,	IB: AB FG-NR.: NSBIT 79210
2 MUTTER	020006	2	1550,551,552, 1553,	
2 MUTTER	288245	2	1555,556,557, 1558,	
3 U-SCHEIBE	012533	2	1550,551,555, 1552,553,557 1556,558,	
4 ZUENDKERZE	289030	1	1550,551,555, 1552,553,557 1556,558,	
5 ZYLINDERKOPF	286534	1	1550,551,552, 1553,	
5 ZYLINDERKOPF	288401	1	1555,556,557, 1558,	
6 MUTTER	288531	4	1550,551,555, 1552,553,557 1556,558,	
7 FEDERRING	078307	2	1550,551,555, 1552,553,557 1556,558,	
8 SCHRAUBE	008375	2	1550,551,555, 1552,553,557 1556,558,	
9 EINLASSMEMBRANE	288836	1	1550,551,555, 1552,553,557 1556,558,	
10 EINLASSSTUTZEN	288606	1	1550,551,552, 1553,	
10 EINLASSSTUTZEN	289354	1	1555,556,557, 1558,	
11 SCHRAUBE	414837	1	1550,551,555, 1552,553,557 1556,558,	
12 ABREISSCHRAUBE	288748	1	1550,551,555, 1552,553,557 1556,558,	
ROHR	289871	1	1550,551,555, 1552,553,557, 1556,558,	
ABDECKUNG	431535	1	1550,551,552, 1553,	
ABDECKUNG	433793	1	1555,556,557, 1558,	

GEN	TAFEL 06	KUPPL.DECKEL / LUEFTERGEH.DECKEL	SPALTE 3A	ABB. BENENNUNG	ERSATZTEIL	ST	KENNZIFFER	BEMERKUNGEN	
EILEN				1 SCHRAUBE	015715	4	1550,552,		
AFELN				1 SCHRAUBE	015856	4	1550,551,555, A	IA: FUER MODELL 550 AB APRIL 1991.	
15.							1552,553,557, 1556,558,		
RIL 94				2 LUEFTERGEHAEUSE-DECKEL	286935	1	1550,551,555, 1552,553,557, 1556,558,		
				3 SCHRAUBE	414835	8	1550,551,555, 1552,553,357 1556,558,		
				4 SCHRAUBE	430264	6	1555,556,557, 1558,		
				5 ABDECKUNG FUER KICKSTARTERVORRICHTUNG	289423	1	1555,556,557, 1558,		
				6 SCHAUMSTOFF-EINSATZ	289153	1	1555,556,557, 1558,		
				7 ABDECKUNG	289498	1	1555,556,557, B	IB: MIB ABB. 6	
				8 SCHEIBE	006975	3	1555,556,557, 1558,		
				9 SCHRAUBE	015123	3	1555,556,557, 1558,		
				10 SCHEIBE	289155	3	1555,556,557, 1558,		
				11 MUTTER	020105	3	1555,556,557, 1558,		
				12 PUFFER	267848	1	1550,555,		
				12 PUFFER	259625	1	1550,551,555, G		
							1552,553,557, 1556,558,		
				13 PLAETTCHEN	286206	1	1550,551,555, 1552,553,557, 1556,558,	IG: AB MOTOR-NR.: NSL1M 53762 NS81M 11292	
				14 PUFFER	286207	1	1550,551,555, 1552,553,557 1556,558,		
				15 KUPPLUNGSDECKEL	430834	1	1550,551,		
				15 KUPPLUNGSDECKEL	434260	1	1552,553, C	IC: AB APRIL 94	
				15 KUPPLUNGSDECKEL	434287	1	1557,558, C		
				15 KUPPLUNGSDECKEL	430837	1	1555,556,		
				16 SCHRAUBE	414838	13	1550,551,555, 1552,553,557 1556,558,		

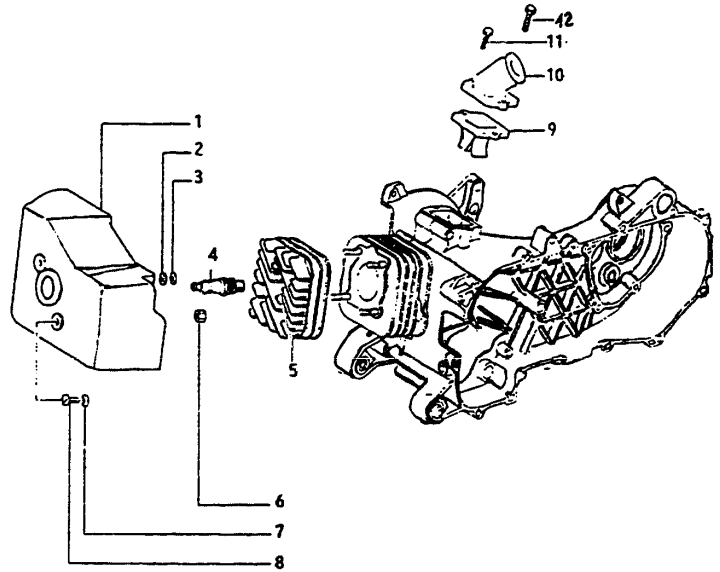
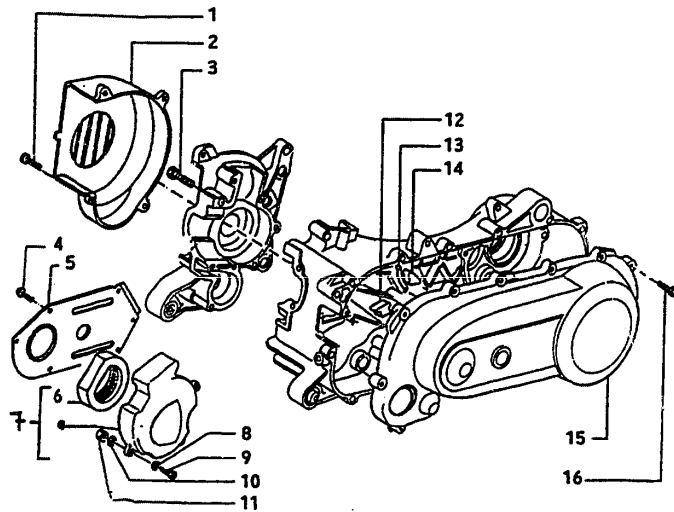

FN	TAFEL 07	GETRIEBENE RIEMENSCHLEIFE	SPALTE 3B	ABB. BENENNUNG	ERSATZTEIL	ST	KENNZIFFER	BEMERKUNGEN	
----	----------	---------------------------	-----------	----------------	------------	----	------------	-------------	--

EN	TAFEL 07	GETRIEBENE RIEMENSCHLEIBE	SPALTE 3B	ABB. BENENNUNG	ERSATZTEIL	ST	IKENNZIFFER	IBEMERKUNGEN	ITAF
B. 2-8				1 DISTANZSCHEIBE	286182	1	1550,551,555, 1552,553,557, 1556,558,		
				2 LAGER	285007	2	1550,551,555, 1552,553,557, 1556,558,		
				3 DICHTUNG	289386	1	1550,551,552, 1553,		
				3 SCHEIBE	289184	1	1555,556,557, 1558,		
				4 DISTANZSTUECK	286183	1	1550,551,555, 1552,553,557, 1556,558,		
				5 GEWINDERING	285017	1	1550,551,555, 1552,553,557, 1556,558,		
				6 SICHERUNGSBLECH	285019	1	1550,551,555, 1552,553,557, 1556,558,		
				7 GETR. RIEMEN- SCHEIBENHAELFTE	287089	1	1550,551,555, 1552,553,557, 1556,558,		
				8 NABE	287088	1	1550,551,552, 1553,		
				8 NABE	430080	1	1555,556,557, 1558,		
				9 ROLLENKERN	285358	2	1550,551,552, 1553,		
				9 ROLLENKERN	285358	3	1555,556,557, 1558,		
				10 ZAPFEN	285359	2	1550,551,552, 1553,		
				10 ZAPFEN	285359	3	1555,556,557, 1558,		
				11 SCHEIBE	288530	2	1550,551,555, 1552,553,557, 1556,558,		
				12 REGELSCHEIBEN- HAELFTE	287090	1	1550,551,552, 1553,	IA: MIT ABB. 11	
				12 REGELSCHEIBEN- HAELFTE	430079	1	1555,556,557, 1558,		
				13 DICHTUNG	289387	2	1550,551,552, 1553,		
				13 DICHTUNG	430585	2	1555,556,557, 1558,		
				14 TELLER	286191	1	1550,551,552, 1553,		
				14 TELLER	289662	1	1555,556,557, 1558,		
				15 FEDER	287011	1	1550,551,552, 1553,		
				15 FEDER	288848	1	1555,556,557, 1558,		
				16 KUPPLUNGSGLOCKE	287028	1	1550,551,555, 1552,553,556,		

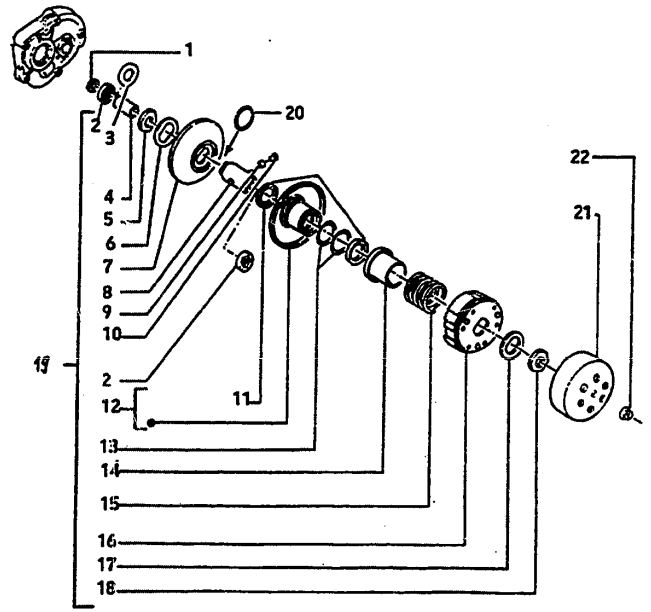

EN	TAFEL 07	GETRIEBENE RIEMENSCHLEIBE	SPALTE 3C	ABB. BENENNUNG	ERSATZTEIL	ST	IKENNZIFFER	IBEMERKUNGEN	ITAF
----	----------	---------------------------	-----------	----------------	------------	----	-------------	--------------	------

UNGEN	TAFEL 07	GETRIEBENE RIEMENSCHLEIBE	SPALTE 3C	ABB. BENENNUNG	ERSATZTEIL	ST	IKENNZIFFER	IBEMERKUNGEN	TAFEL
DEN KATE- IEN 1,2,3 R 4 BEST.				16 KUPPLUNGSGLOCKE	431631	1	1555,556,	IG: AB MOTOR-NR.: NS81M 24810	
				16 KUPPLUNGSGLOCKE	433919	1	1555,556,557, 1558,		
				17 SICHERUNGSBLECH	285019	1	1550,551,555, 1552,553,557, 1556,558,	IF: AB MOTOR-NR.: NS81M 82366	
				18 GEWINDERING	285017	1	1550,551,555, 1552,553,557, 1556,558,		
ABB. 3				19 GETRIEB. RIEMEN- SCHEIBE KPL.	287033	1	1550,551,552, 1553,	IB: MIT ABB. 2-18	
				19 GETRIEB. RIEMEN- SCHEIBE KPL.	430081	1	1555,	IC: MIT ABB.2-18, 23.	
				19 GETRIEB. RIEMEN- SCHEIBE KPL.	431632	1	1555,556,	II: AB MOTOR-NR.: NS81M 24003	
ABB. 4				19 GETRIEB. RIEMEN- SCHEIBE KPL.	434137	1	1555,556,557, 1558,		
				20 DICHTUNG	289386	1	1555,556,557, 1558,		
				21 KUPPLUNGSTROMMEL	287106	1	1550,555,		
				21 KUPPLUNGSTROMMEL	433921	1	1555,556,		
				21 KUPPLUNGSTROMMEL	431640	1	1550,551,555, 1552,553,557, 1556,558,	IH: AB FG-NR.: NSLIT 86723 NS81T 1664+	
				22 MUTTER	289519	1	1550,551,555, 1552,553,557, 1556,558,		
				SPEZIALFETT MONT BLANK MOLYBDENUM GREASE TUBENINHALT: 30g	498345	1	1550,551,555, 1552,553,557, 1556,558,	IE: FUER GETRIEB. RIEMENSCHLEIBE	

UNGEN	TAFEL 08	TREIBENDE RIEMENSCHLEIBE	SPALTE 3D	ABB. BENENNUNG	ERSATZTEIL	ST	IKENNZIFFER	IBEMERKUNGEN	TAFEL
-------	----------	--------------------------	-----------	----------------	------------	----	-------------	--------------	-------

INGEN	TAFEL 08	TREIBENDE RIEMENSCHLEIBE	SPALTE 3D	IABB. BENENNUNG	ERSATZTEIL	ST	IKENNZIFFER	IBEMERKUNGEN	TAFEL
				1 DISTANZSTUECK	287061	1	1550,551,555, 1552,553,557		
				2 RIEMENSCHLEIBE F. OELPUMPE	286158	1	1550,551,555, 1552,553,557, 1556,558		
				3 SCHRAUBE	015947	3	1550,551,555, 1552,553,557, 1556,558		
				4 U-SCHLEIBE	006964	3	1550,551,555, 1552,553,557, 1556,558		
				5 DECKEL	286271	1	1550,551,555, 1552,553,557, 1556,558		
				6 DICHTUNG	285430	1	1550,551,555, 1552,553,557, 1556,558		
				7 GLEITLAGER	285396	3	1550,551,555, 1552,553,557, 1556,558		
				8 ROLLENAUFNAHME-PLATTE	285394	1	1550,551,555, 1552,553,557, 1556,558		
				9 ROLLE	286870	6	1551,551,552, 1553,		
				9 ROLLE	289101	6	1555,556,557, 1558,		
				10 ROLLEUEBERZUG	285434	12	1550,551,555, 1552,553,557, 1556,558		
				11 BUCHSE	287062	1	1550,551,555, 1552,553,557, 1556,558		
				12 REGLERGEHAUSE-HAELFTE	287057	1	1550,551,555, 1552,553,557, 1556,558		
				13 TREIBENDE RIEMENSCHLEIBENHAELFTE KPL.	287056	1	1550,551,552, 1553,	IA: MIT ABB. 3-12	
				13 TREIBENDE RIEMENSCHLEIBENHAELFTE KPL.	289100	1	1555,556,557, 1558,		
				14 RIEMENSCHLEIBENHAELFTE	286170	1	1550,551,555, 1552,553,557, 1556,558		
				15 KEILRIEMEN, VERZ.	430719	1	1550,551,555, 1552,553,557, 1556,558		
				16 AUFNAHMEPLATTE	287044	1	1550,551,552, 1553,		
				16 AUFNAHMEPLATTE	289104	1	1555,556,557, 1558,		

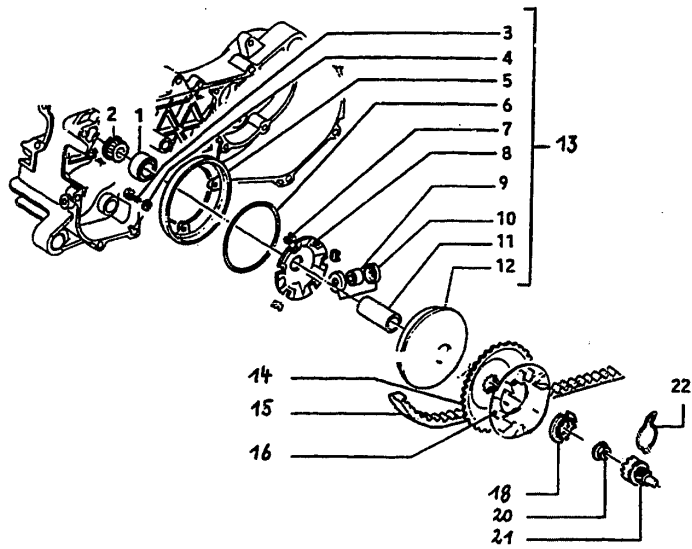

MOTOR-NR.:
M 81067

ABB. 2-4

IN KATE-
3 OD. 4
ELLEN.

ABB. 5+6

INGEN	TAFEL 08	TREIBENDE RIEMENSCHLEIBE	SPALTE 3E	IABB. BENENNUNG	ERSATZTEIL	ST	IKENNZIFFER	IBEMERKUNGEN	TAFEL
-------	----------	--------------------------	-----------	-----------------	------------	----	-------------	--------------	-------

NGEN	TAFEL 08 TREIBENDE RIEMENSCHLEIBE	SPALTE 3E	I ABB. BENENNUNG	I ERSATZTEIL	I ST IKENNZIFFER	I BEMERKUNGEN
AI 93			18 VERZAHNTE BUCHSE	288694	1 1550,551,555, 1552,553,557, 1556,558,	
			20 MUTTER	289519	1 1550,551,555, 1552,553,557, 1556,558,	
3-NR.: 79210			21 ANLASSERRITZEL	288696	1 1550,551,555, 1552,553,557, 1556,558,	
			22 SICHERUNGSFEDER	288673	1 1550,551,555, 1552,553,557, 1556,558,	

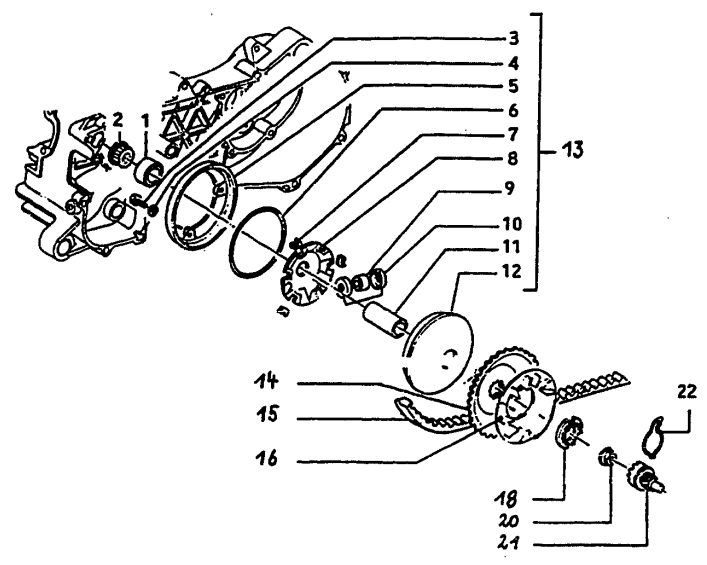

TAFEL 09	HINTERRADACHSE	SPALTE 3F	I ABB. BENENNUNG	I ERSATZTEIL	I ST IKENNZIFFER	I BEMERKUNGEN
----------	----------------	-----------	------------------	--------------	------------------	---------------

TAFEL 09	HINTERRADACHSE	SPALTE 3F	I ABB. BENENNUNG	I ERSATZTEIL	I ST IKENNZIFFER	I BEMERKUNGEN
			1 SPLINT	012789	1 1550,551,555, 1552,553,557 1556,558,	
			2 KAPPE	194423	1 1550,551,555, 1552,553,557 1556,558,	
			3 MUTTER	194424	1 1550,551,555, 1552,553,557 1556,558,	
			4 U-SCHEIBE	159347	1 1550,551,555, 1552,553,557 1556,558,	
			5 LAGER	288502	1 1550,551,555, 1552,553,557 1556,558,	
			6 STARTERWELLE	286930	1 1550,551,552, 1553,	
			6 STARTERWELLE	288602	1 1555,556,557, 1558,	
			7 DICHRING	239848	1 1550,551,555, 1552,553,557 1556,558,	
			8 SPRENGRING	288812	1 1550,551,555, 1552,553,557 1556,558,	
			9 LAGER	288476	1 1550,551,555, 1552,553,557 1556,558,	
			10 ZAHNRAD	286927	1 1550,551,552, 1553,	
			10 ZAHNRAD	288608	1 1555,556,557, 1558,	
			11 DISTANZSCHEIBE	288639	2 1550,551,555, 1552,553,557 1556,558,	
			12 DECKEL FUER ANTRIEBSWELLE	286922	1 1550,551,555, 1552,553,557, 1556,558,	IA: MIT ABB. 13
			13 ROLLENKAEFIG	224309	1 1550,551,555, 1552,553,557 1556,558,	
			14 SCHRAUBE	414834	5 1550,551,555, 1552,553,557 1556,558,	
			15 ZAHNRAD	287048	1 1550,551,555, 1552,553,557 1556,558,	
			16 SPRENGRING	006419	2 1550,551,555, 1552,553,557 1556,558,	
			17 ANTRIEBSWELLE	287047	1 1550,551,552, 1553,	
			17 ANTRIEBSWELLE	289132	1 1555,556,557, 1558,	
			18 DICHRING	008714	1 1550,551,555, 1552,553,557 1556,558,	

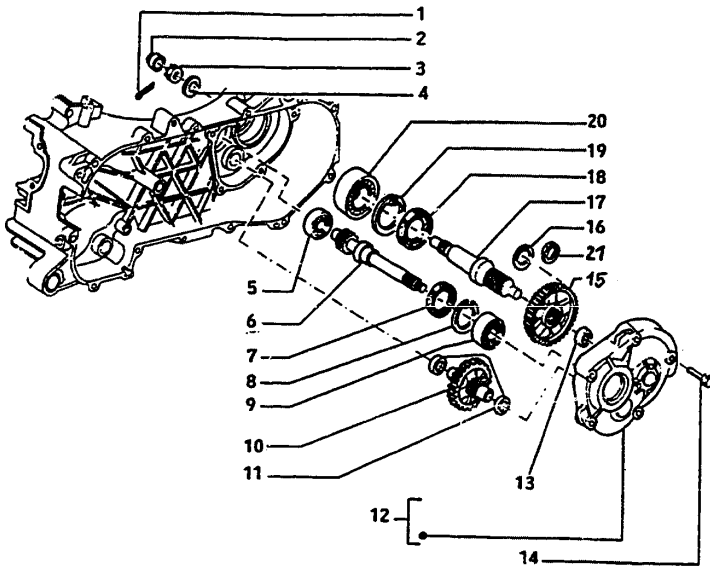

TAFEL 09	HINTERRADACHSE	SPALTE 3G	I ABB. BENENNUNG	I ERSATZTEIL	I ST IKENNZIFFER	I BEMERKUNGEN
----------	----------------	-----------	------------------	--------------	------------------	---------------

TAFEL 09	HINTERRADACHSE	SPALTE 3G	ABB. BENENNUNG	ERSATZTEIL	ST. IKENNZIFFER	BEMERKUNGEN
			19 SPRENGRING	006647	1 1550,551,555, 1552,553,557 1556,558,	
			20 LAGER	245255	1 1550,551,555, 1552,553,557 1556,558,	
			21 SCHEIBE	289133	1 1555,556,557, 1558,	

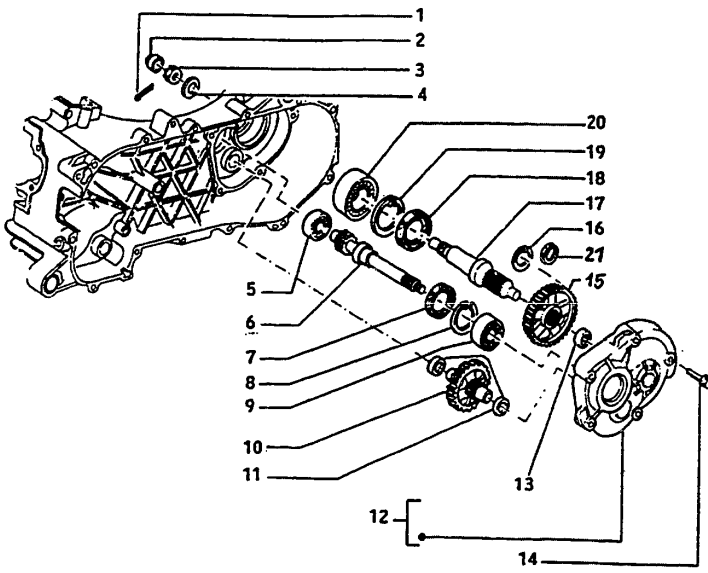

TAFEL 10	LICHTMASCHINE	SPALTE 3H	ABB. BENENNUNG	ERSATZTEIL	ST. IKENNZIFFER	BEMERKUNGEN
----------	---------------	-----------	----------------	------------	-----------------	-------------

TAFEL 10	LICHTMASCHINE	SPALTE 3H	I ABB. BENENNUNG	I ERSATZTEIL	I ST IKENNZIFFER	IBEMERKUNGEN
			1 FEDERRING	006965	8 1550,551,555, 1552,553,557, 1556,558,	
			2 SCHRAUBE	015856	3 1550,551,555, 1552,553,557, 1556,558,	
			3 SCHRAUBE	015585	2 1550,551,555, 1552,553,557, 1556,558,	
			4 U-SCHEIBE	286328	1 1550,551,555, 1552,553,557, 1556,558,	
			5 MUTTER	021110	1 1550,551,555, 1552,553,557, 1556,558,	
			6 LUEFTERRAD	289338	1 1550,551,555, 1552,553,557, 1556,558,	
			7 SCHRAUBE ZUR LUEFTERRADBEFEST.	015585	3 1550,551,555, 1552,553,557, 1556,558,	
			8 ROTOR	290882	1 1550,551,555, 1552,553,557, 1556,558,	
			9 ANKERPLATTE	290885	1 1550,551,555, 1552,553,557, 1556,558,	IA: MIT ABB. 10
			10 PICK UP	290290	1 1550,551,555, 1552,553,557, 1556,558,	
			11 LICHTMASCHINE KPLI	290884	1 1550,551,555, 1552,553,557, 1556,558,	IB: MIT ABB. 8+9
			12 SCHEIBENFEDER	000267	1 1550,551,555, 1552,553,557, 1556,558,	

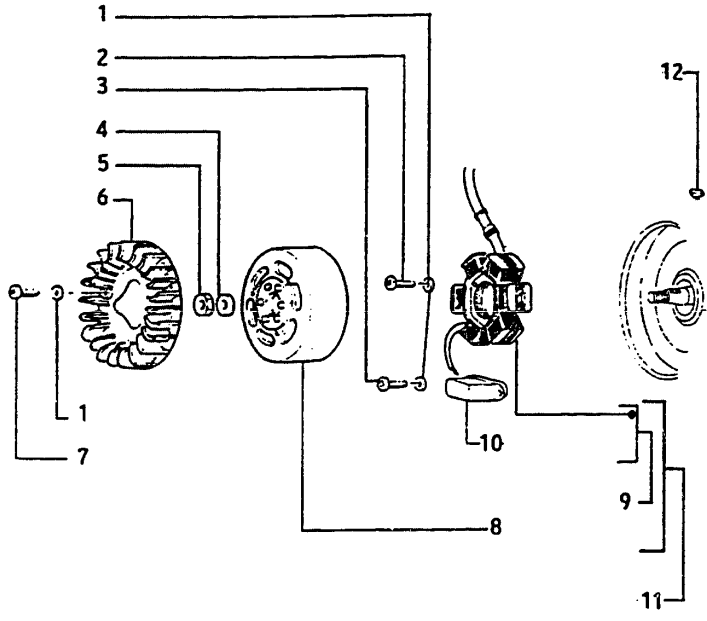

TAFEL 11	ANLASSERMOTOR / KICKSTARTER	SPALTE 3I	I ABB. BENENNUNG	I ERSATZTEIL	I ST IKENNZIFFER	IBEMERKUNGEN
----------	-----------------------------	-----------	------------------	--------------	------------------	--------------

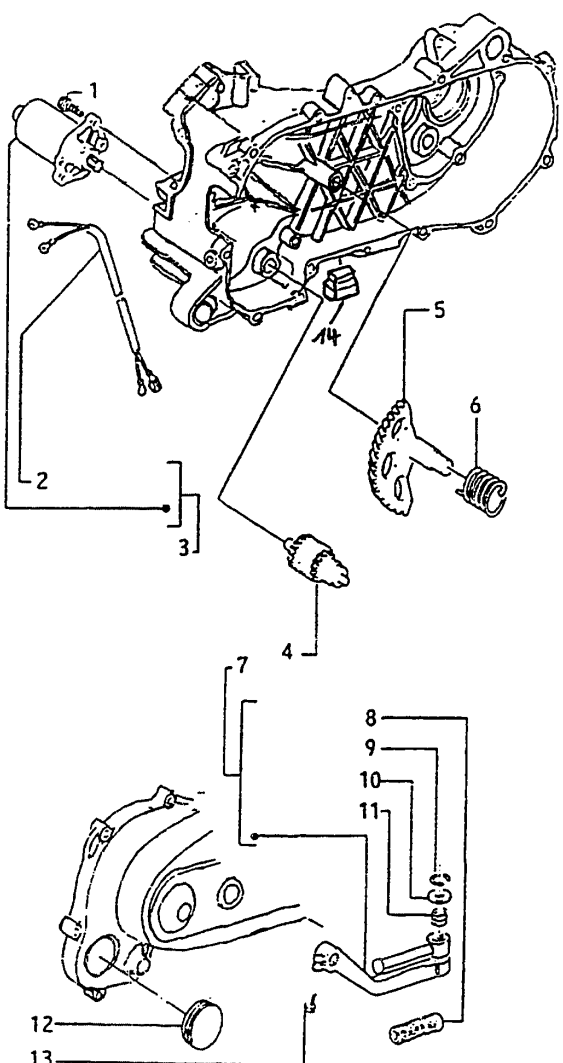
TAFEL 11	ANLASSERMOTOR / KICKSTARTER	SPALTE 31	I ABB. BENENNUNG	I ERSATZTEIL	I ST I KENNZIFFER	I BEMERKUNGEN
			1 SCHRAUBE	031091	2 1550,551,555, 1552,553,557, 1556,558,	
			2 KABELAST	291072	1 1550,551,555, 1552,553,557, 1556,558,	
			3 ANLASSERMOTOR KPL.	286172	1 1550,551,552, 1553,	IA: MIT ABB. 2
			3 ANLASSERMOTOR KPL.	286808	1 1555,556,557, 1553,	
			4 RITZEL	286174	1 1550,551,552, 1553,	
			4 RITZEL	289202	1 1555,556,557, 1558,	
			5 KICKSTARTER-SEGMENT	286210	1 1550,551,555, 1556,	
			5 KICKSTARTER-SEGMENT	432054	1 1550,551,555, 1556,552,553, 1557,558,	ID: AB MAERZ 94
			6 FEDER	289495	1 1550,551,555, 1552,553,557, 1556,558,	
			7 KICKSTARTERHEBEL KPL.	286214	1 1550,551,555, 1552,553,557, 1556,558,	
			8 GUMMIEBERZUG F. KICKSTARTERHEBEL	286217	1 1550,551,555, 1552,553,557, 1556,558,	IB: MIT ABB. 8-11
			9 SPRENGRING	288041	1 1550,551,555, 1552,553,557, 1556,558,	
			10 U-SCHEIBE	286219	1 1550,551,555, 1552,553,557, 1556,558,	
			11 FEDER	286218	1 1550,551,555, 1552,553,557, 1556,558,	
		12 PFROPFEN	287020	1 1550,551,555, 1552,553,557, 1556,558,		
		13 SCHRAUBE FUER KICKSTARTERHEBEL	414837	1 1550,551,555, 1552,553,557, 1556,558,		
		14 ANSCHLAGGUMMI F. HAUPTSTAENDER	259625	1 1550,551,555, 1552,553,557, 1556,558,		
		SCHELLE ZUR BEFEST. DER ANLASSERMOTORKABEL	216983	1 1550,551,555, 1552,553,557, 1556,558,	IC: AB FEBRUAR 92	
		SCHRAUBE FUER SCHELLE	292179	1 1550,551,555, 1552,553,557, 1556,558,		
		MUTTER F. SCHELLE	020106	1 1550,551,555, 1552,553,557, 1556,558,		

TAFEL 11	ANLASSERMOTOR / KICKSTARTER	SPALTE 3J	I ABB. BENENNUNG	I ERSATZTEIL	I ST IKENNZIFFER	I BEMERKUNGEN
			FEDERRING FUER SCHELLE	016406 C	1 1550,551,555, 1552,553,557, 1556,558,	
			FEDERRING FUER KICKSTARTER-SEGMENT	433987 D	1 1550,551,552, 1553,555,556, 1557,558,	ID: AB MAERZ 94
			SPRENGRING FUER KICKSTARTER-SEGMENT	006416 D	1 1550,551,552, 1553,555,556, 1557,558,	

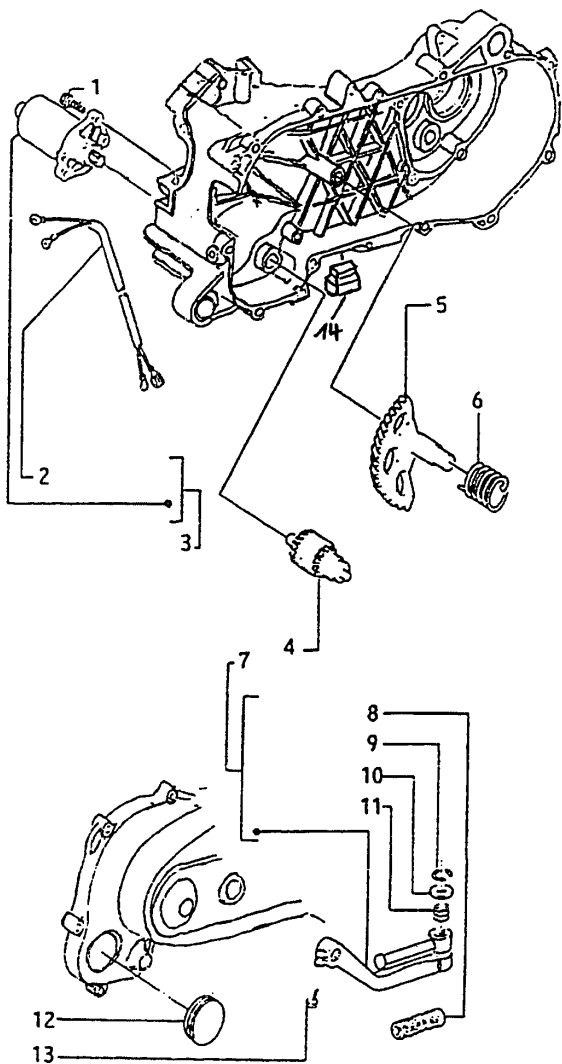

TADEL 12	OELPUMPE	SALTE 3K	ABB. BENENNUNG	ERSATZTEIL	ST	KENNZIFFER	IBEMERKUNGEN
			1 KABELDURCHGANG	287021	1	1550,551,555, 1552,553,557 1556,558,	
			2 U-SCHEIBE	287073	1	1550,551,555, 1552,553,557 1556,558,	
			3 ZAHNRAD	289191	1	1550,551,555, 1552,553,557 1556,558,	
			4 KEILRIEMEN, VERZ.	286162	1	1550,551,555, 1552,553,557 1556,558,	
			5 PLATTE	286163	1	1550,551,555, 1552,553,557 1556,558,	
			6 DECKEL	288612	1	1550,551,555, 1552,553,557 1556,558,	
			7 FEDERRING	006975	3	1550,551,555, 1552,553,557 1556,558,	
			8 SCHRAUBE	015856	1	1550,551,552, 1553,	
			8 SCHRAUBE	015585	1	1555,556,557, 1558,	
			9 SCHELLE	104296	1	1550,551,555, 1552,553,557 1556,558,	
			10 SCHRAUBE ZUR OELPUMPENBEFEST.	015856	2	1550,551,555, 1552,553,557, 1556,558,	
			11 SCHLAUCH	286165	1	1550,551,555, 1552,553,557 1556,558,	
			12 SCHLAUCH	288649	1	1550,551,555, 1552,553,557 1556,558,	
			13 OELPUMPE KPL.	288737	1	1550,551,552, 1553,	IA: MIT ABB.11+12
			13 OELPUMPE KPL.	289093	1	1555,556,557, 1558,	
			SCHELLE	431918	1	1550,551,555, 1552,553,557, 1556,558,	IB: AB NOV. 92
			SCHELLE	288327	1	1550,551,555, 1552,553,557, 1556,558,	

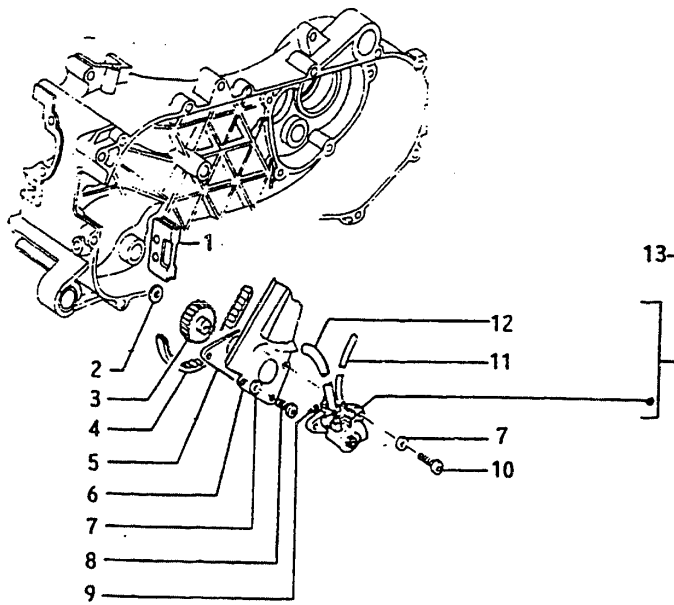

TAFEL 13

BREMSHEBEL FUER HINTERRAD

SPALTE 3L



ABB. BENENNUNG	ERSATZTEIL	ST	KENNZIFFER	BEMERKUNGEN
1 BREMSBACKE F. HINTERRAD	267599 A	2	1550,551,555, 1552,553,557, 1556,558,	IA: MIT ABB. 2
2 BREMSBACKENSCHUH	266724	2	1550,551,555, 1552,553,557 1556,558,	
3 FEDER	266725	2	1550,551,552, 1553,	
3 FEDER	268556	2	1555,556,557, 1558,	
4 BREMSNOCKEN	266533	1	1550,551,555, 1552,553,557 1556,558,	
5 SCHRAUBE	414837	1	1550,551,555, 1552,553,557 1556,558,	
6 MUTTER	709041	1	1550,551,555, 1552,553,557 1556,558,	
7 BREMSHEBEL	266610	1	1550,551,555, 1552,553,557 1556,558,	
8 OELPFROPFEN	138345	2	1550,551,555, 1552,553,557 1556,558,	
9 DICHTUNG	000397	2	1550,551,555, 1552,553,557 1556,558,	

I

I

I

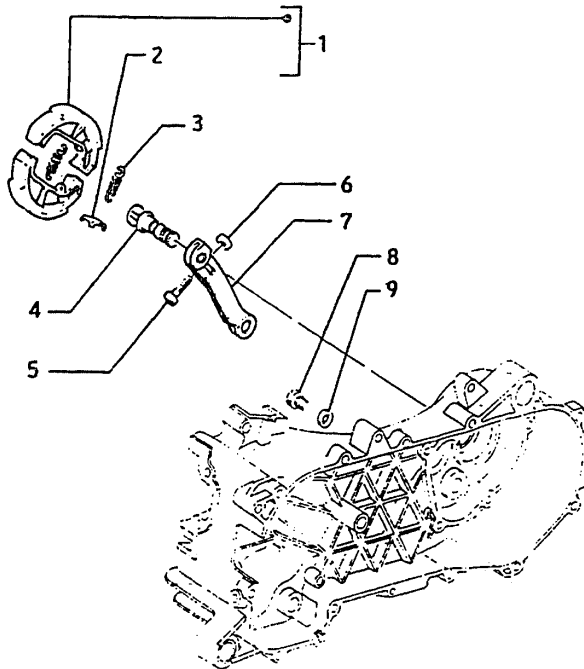
I

I

I

I

N	TAFEL 14	VERGASER	SPALTE 4A	ABB. BENENNUNG	ERSATZTEIL	ST	IKENNZIFFER	IBEMERKUNGEN	TAF
				1 VERGASER KPL.	432730	1	1550,552,	IA: MIT TEILEN D.	
					A			TAFEL 15 UND	
DELL				1 VERGASER KPL.	432310	1	1551,553,	ABB. 3 DER	
APRIL				KAT-VERSION	A			TAFEL 35.	
				1 VERGASER KPL.	432728	1	1555,557,		
					A				
				1 VERGASER KPL.	432738	1	1556,558,		
				KAT-VERSION	A				
				2 SCHELLE	109960	1	1550,551,555,		
							1552,553,557		
							1556,558,		
				3 MUFFE	257841	1	1550,551,555,		
							1552,553,557		
							1556,558,		
				4 SCHELLE	109960	1	1550,551,555,		
							1552,553,557		
							1556,558,		
				5 DICHTUNGSSATZ F.	498336	1	1550,551,555,		
				VERGASER			1552,553,557,		
							1556,558,		
				6 SCHELLE	288741	1	1550,551,555,		
							1552,553,557		
							1556,558,		
				VERGASERANWAERM-	498399	1	1550,551,552,		
				SATZ			1553,		

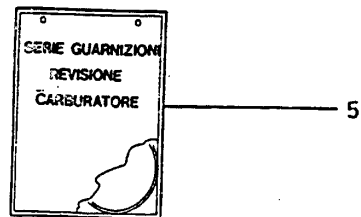
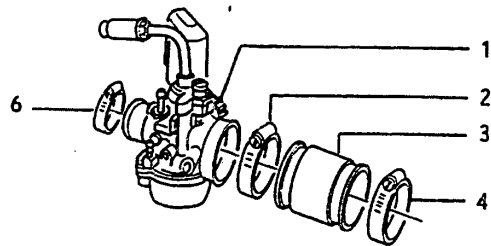

6

3-NR. :
3762
1292

94

TAFEL 15 VERGASER - BESTANDTEILE SPALTE 4B



ABB. BENENNUNG	ERSATZTEIL	ST	KENNZIFFER	BEMERKUNGEN
1 FUEHRUNGSRÖHR	113903	1	1550,551,555, 1552,553,557 1556,558,	
2 GASSCHIEBERDECKEL	288864	1	1550,551,555, 1552,553,557 1556,558,	
3 FEDER	288875	1	1550,551,555, 1552,553,557 1556,558,	
4 ABDECKKAPPE	288883	1	1550,551,555, 1552,553,557 1556,558,	
5 KALTSTARTVORRICHTUNG	288866	1	1550,551,555, 1552,553,557, 1556,558,	
6 SCHRAUBE	010028	2	1550,551,552, 1553,	
6 SCHRAUBE	289575	2	1555,556,557, 1558,	
7 HALTERUNG	288863	1	1550,551,555, 1552,553,557 1556,558,	
8 LEERLAUFDUESE 34	288869	1	1550,551,555, 1552,553,557 1556,558,	
9 SCHWIMMERNADEL	247654	1	1550,551,555, 1552,553,557 1556,558,	
10 SCHRAUBE	288862	2	1550,551,555, 1552,553,557 1556,558,	
11 SCHWIMMERGEHÄUSE M. ABLASSSCHRAUBE	431653	1	1550,551,555, 1552,553,557, 1556,558,	
12 SCHWIMMER	288882	1	1550,551,555, 1552,553,557 1556,558,	
13 ZAPFEN	288881	1	1550,551,555, 1552,553,557 1556,558,	
14 STARTERDUESE 50	289471	1	1550,555,	
14 STARTERDUESE 60	431635	1	1550,551,555, 1552,553,557, 1556,558,	IA: AB FG-NR.: NSLIT 91225
15 HAUPTDUESE 60	240006	1	1550,552,	
15 HAUPTDUESE 54 KAT-VERSION	241126	1	1551,553,	
15 HAUPTDUESE 65	289608	1	1555,556,557, 1558,	IB: AUCH FUER SFERA 80 KAT.
16 MISCHERROHR FA2111	288870	1	1550,551,552, 1553,	
16 MISCHERROHR FA2101	289609	1	1555,556,557, 1558,	

GEN	TAFEL 15	VERGASER - BESTANDTEILE	SPALTE 4C	ABB. BENENNUNG	ERSATZTEIL	ST	IKENNZIFFER	BEMERKUNGEN	TAFEL
OTOR-NR.: 1 24810				17 GASSCHIEBER	288874	1	1550,551,552, 1553,		
				17 GASSCHIEBER	289611	1	1555,556,557, 1558,		
OTOR-NR.: 1 82366				18 FEDER	085285	1	1550,551,555, 1552,553,557		
				19 FEDER	152608	1	1550,551,555, 1552,553,557		
ABB. 2-18				20 LEERLAUFEINSTELL- SCHRAUBE	288880	1	1550,551,555, 1552,553,557, 1556,558,		
ABB. 2-18				21 KAPPE	288878	1	1550,551,555, 1552,553,557		
OTOR-NR.: 1 24003				22 LUFTREGULIER- SCHRAUBE	288879	1	1550,551,555, 1552,553,557, 1556,558,		
				23 DUESENNADEL (2)	288871	1	1550,551,552, 1553,		
				23 DUESENNADEL (7)	289920	1	1550,556,557, 1558,		
				24 SICHERUNGSSCHEIBE	268872	1	1550,551,555, 1552,553,557		
				25 BUCHSE	288873	1	1550,551,555, 1552,553,557		
-NR.: 86723 1664+				26 SCHRAUBE	288865	1	1550,551,555, 1552,553,557		
				KAPPE F. GASSEIL	289903	1	1550,551,552, 1553,	IA: AB JUNI 91	
GETRIEB. NSCHEIBE									

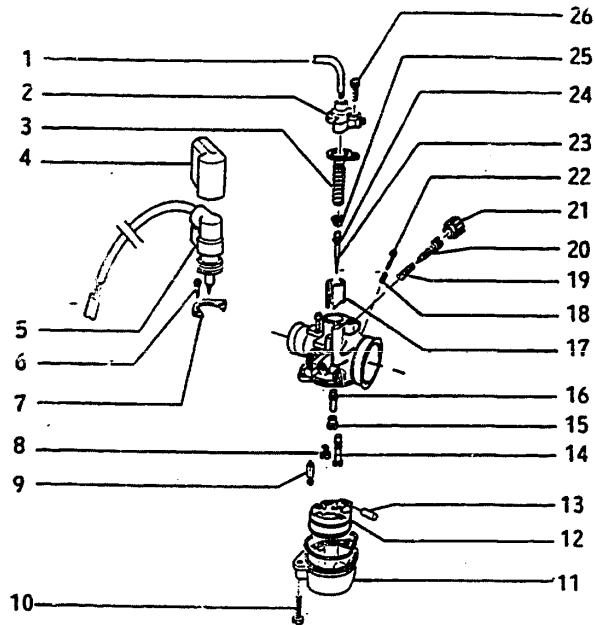
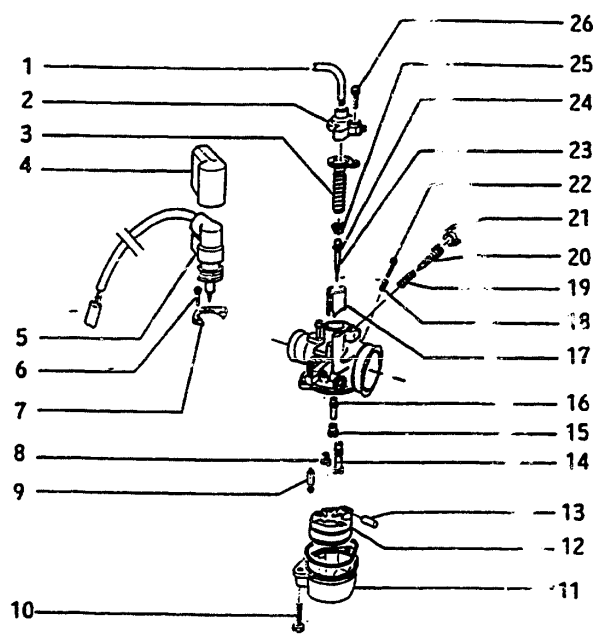

GEN	TAFEL 16	LUFTFILTER	SPALTE 4D	ABB. BENENNUNG	ERSATZTEIL	ST	IKENNZIFFER	BEMERKUNGEN	TAFEL
-----	----------	------------	-----------	----------------	------------	----	-------------	-------------	-------

GEN	TAFEL 16	LUFTFILTER	SPALTE 4D	I ABB. BENENNUNG	I ERSATZTEIL	I ST IKENNZIFFER	I BEMERKUNGEN	I TAFEL
				1 LUFTFILTER KPL.	258728	1 1550,555,	IA: MIT ABB. 2-4	
				1 LUFTFILTER KPL.	417526	1 1550,551,555,	IB: AB JULI 1991	
						1552,553,557,		
						1556,558,		
				2 PLAETTCHEN	254485	1 1550,551,555,		
						1552,553,557		
						1556,558,		
				3 LUFTFILTERELEMENT	257363	1 1550,551,555,		
						1552,553,557		
						1556,558,		
				4 DICHTUNG	257370	1 1550,551,555,		
						1552,553,557		
						1556,558,		
				5 U-SCHEIBE	013880	2 1550,551,555,		
						1552,553,557		
						1556,558,		
				5 U-SCHEIBE	006125	1 1550,551,552,	IC: ZUSAMMEN MIT	
						1553,	SCHRAUBE	
				6 SCHRAUBE	290833	2 1550,551,552,	ET-NR: 290833	
						1553,	VERBAUEN.	
				7 SCHRAUBE	267115	5 1550,551,555,		
						1552,553,557		
						1556,558,		
				8 U-SCHEIBE	013769	5 1550,551,555,		
						1552,553,557		
						1556,558,		
				9 FEDERRING	012533	2 1550,551,555,		
						1552,553,557,		
						1556,558,		

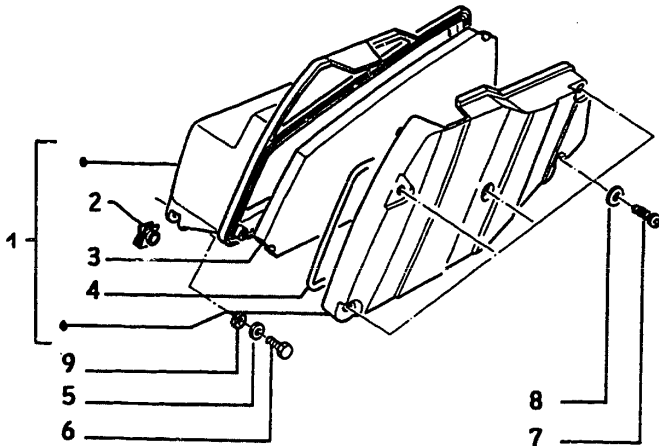

EN	TAFEL 17	SCHALLDAEMPFER	SPALTE 4E	I ABB. BENENNUNG	I ERSATZTEIL	I ST IKENNZIFFER	I BEMERKUNGEN	I TAFEL
----	----------	----------------	-----------	------------------	--------------	------------------	---------------	---------

EN	TAFEL 17	SCHALLDAEMPFER	SPALTE 4E	I ABB. BENENNUNG	I ERSATZTEIL	I ST	IKENNZIFFER	IBEMERKUNGEN	I TA
				1 AUSPUFFTOPF	434329	1	1550,552,		
				1 AUSPUFFTOPF	431854	1	1555,557,		
				1 AUSPUFFTOPF M.KAT	434629	1	1551,553,		
				1 AUSPUFFTOPF M.KAT	433309	1	1556,558,		
				2 U-SCHEIBE	003058	1	1550,551,555,		
							1552,553,557		
				3 FEDERRING	016408	2	1550,551,555,		
							1552,553,557		
				4 SCHRAUBE	015792	1	1550,551,555,		
							1552,553,557		
				5 AUSPUFFBLENDE	257712	1	1550,551,555,		
							1552,553,557		
				6 U-SCHEIBE	003054	3	1550,551,552,		
							1553,		
				6 U-SCHEIBE	709501	3	1555,556,557,		
							1558,		
				7 SCHRAUBE	256212	3	1550,551,552,		
							1553,		
				7 SCHRAUBE	256756	3	1555,556,557,		
							1558,		
				8 FEDERRING	016404	3	1550,551,555,		
							1552,553,557		
							1556,558,		
				9 SCHRAUBE	018584	1	1550,551,555,		
							1552,553,557		
							1556,558,		
				10 U-SCHEIBE	013861	1	1550,551,555,		
							1552,553,557		
							1556,558,		
				11 DICHTUNG	259307	1	1550,551,552,		
							1553,		
				11 DICHTUNG	259310	1	1555,556,557,		
							1558,		
				12 KRUEMMER	258981	1	1550,551,552,		
							1553,		
				12 KRUEMMER	258611	1	1555,556,557,		
							1558,		
				13 FEDERRING	016406	2	1550,551,555,		
							1552,553,557		
							1556,558,		
				14 SCHRAUBE	259274	2	1551,553,		
				14 SCHRAUBE	031089	2	1550,555,556,		
							1552,557,558,		
				15 MUTTER	020006	2	1550,552,555,		
							1557,		
				15 MUTTER	288245	2	1551,556,553,		
							1558,		

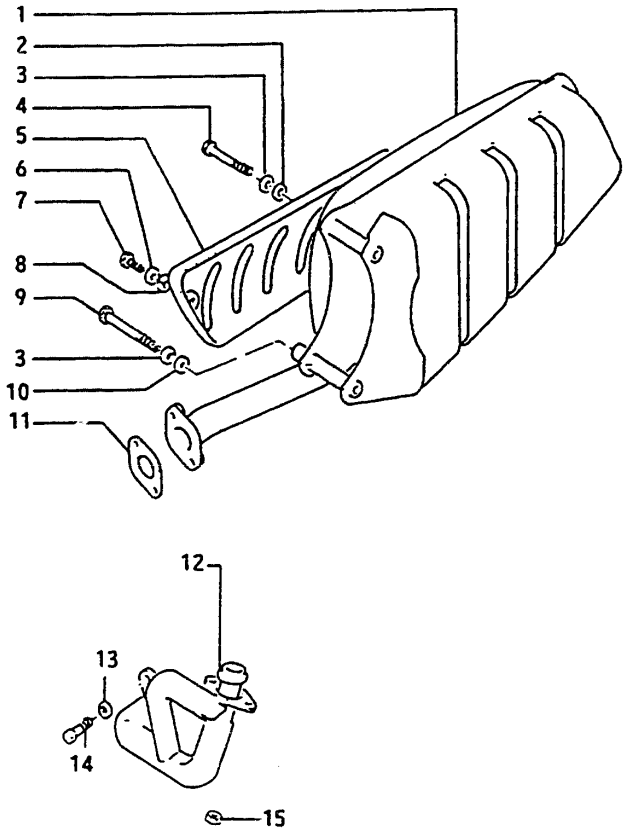

N	TAFEL 17	SCHALLDAEMPFER	SPALTE 4F	I ABB. BENENNUNG	I ERSATZTEIL	I ST	IKENNZIFFER	IBEMERKUNGEN	I TA
---	----------	----------------	-----------	------------------	--------------	------	-------------	--------------	------

N	I	TAFEL 17	SCHALLDAEMPFER	SPALTE 4F	I ABB. BENENNUNG	I ERSATZTEIL	I ST	I KENNZIFFER	I BEMERKUNGEN	I
					HITZESCHILD FUER SCHALLDAEMPFER	432002	1	1551, 556, 553, 1558,		
					SCHRAUBE ZUR BEFESTIGUNG DES HITZESCHILDS	256756	7	1551, 556, 553, 1558,		
					FEDERRING	016404	7	1551, 556, 553, 1558,		

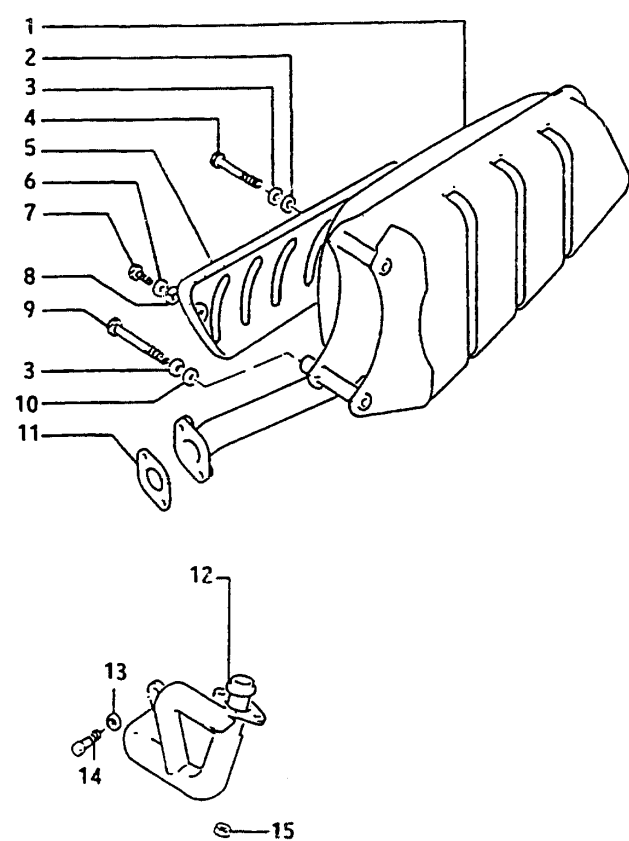

13

EN D.
UND
ER

I TAFEL 18 FAHRGESTELL / MOTORAUFNAHME SPALTE 5A

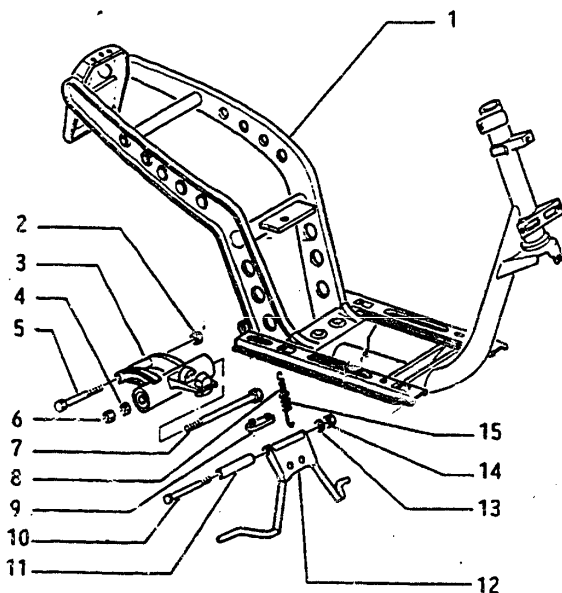

ABBN.	BENENNUNG	ERSATZTEIL	ST	KENNZIFFER	BEMERKUNGEN
1	FAHRGESTELL (ALT)	295536	1	1550,555,	
1	FAHRGESTELL (NEU)	295814	1	1550,551,555,	IA: AB MAI 93
			A	1552,553,557,	
				1556,558,	
2	MUTTER	232108	1	1550,551,555,	
				1552,553,557	
				1556,558,	
3	MOTORAUFNAHME	268892	1	1550,551,555,	
				1556,	
3	MOTORAUFNAHME	272929	1	1550,551,555,	IB: AB JULI 93
			B	1552,553,557,	
				1556,558,	
4	U-SCHEIBE	003060	1	1550,551,555,	
				1552,553,557	
				1556,558,	
5	SCHRAUBE	266775	1	1550,551,555,	
				1552,553,557	
				1556,553,	
6	MUTTER	232108	1	1550,551,555,	
				1552,553,557	
				1556,558,	
7	SCHRAUBE	266774	1	1550,551,555,	
				1552,553,557	
				1556,558,	
8	FEDER	268419	1	1550,551,555,	
				1552,553,557	
				1556,558,	
9	PUFFER	268205	1	1550,551,555,	
				1552,553,557	
				1556,558,	
10	SCHRAUBE	224368	1	1550,551,555,	
				1552,553,557	
				1556,558,	
11	DISTANZSTUECK	267832	1	1550,551,555,	
				1552,553,557	
				1556,558,	
11	DISTANZSTUECK	271584	1	1550,551,555,	
				1552,553,557	
			B	1556,558,	
12	KIPPSTAENDER	259209	1	1550,555,	
12	KIPPSTAENDER	271200	1	1551,553,556,	
				1558,	
13	U-SCHEIBE	003058	1	1550,551,555,	
				1552,553,557	
				1556,558,	
14	MUTTER	195483	1	1550,551,552,	
				1553,	
14	MUTTER	020008	1	1555,556,557,	
				1558,	
15	FEDER	268207	1	1550,552,555,	
				1557,	
15	FEDER	272912	2	1551,553,556,	
				1558,	
	SPRENGRING FUER HAUPTSTAENDER-	271695	2	1550,551,555,	
				1552,553,557,	

I TAFEL 18 FAHRGESTELL / MOTORAUFNAHME SPALTE 5B

I ABB. BENENNUNG I ERSATZTEIL I ST I KENNZIFFER I BEMERKUNGEN I



ABB. BENENNUNG	ERSATZTEIL	ST	KENNZIFFER	BEMERKUNGEN
BEFESTIGUNG			1556,552,	
FUSSRASTENHALTER	259000	1	1550,551,555,	
			1552,553,557	
			1556,558,	
FUSSRASTE LI	258775	1	1550,551,555,	
			1552,553,557	
			1556,558,	
FUSSRASTE RE	258776	1	1550,551,555,	
			1552,553,557	
			1556,558,	
FEDER	258778	2	1550,551,555,	
			1552,553,557	
			1556,558,	
BEFEST. PLATTE	258777	2	1550,551,555,	
			1552,553,557	
			1556,558,	
SCHRAUBE	015558	2	1550,551,555,	
			1552,553,557	
			1556,558,	
U-SCHEIBE	003056	2	1550,551,555,	
			1552,553,557	
			1556,558,	

25

KAT.

I TAFEL 19 FRONT - VERKLEIDUNGSELEMENTE SPALTE 5C

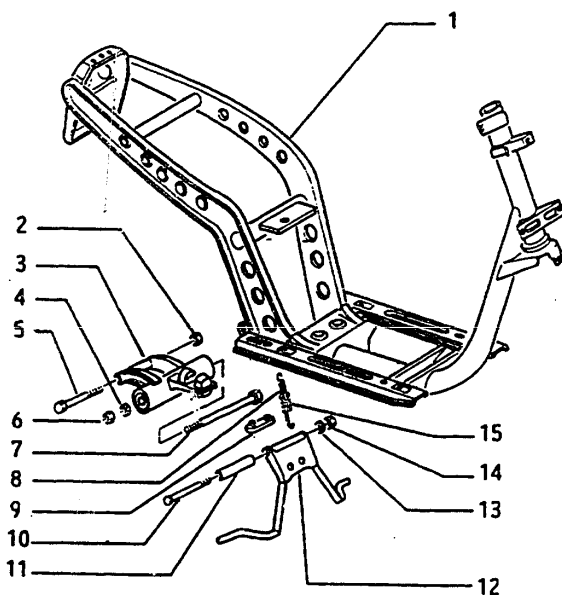
I ABB. BENENNUNG I ERSATZTEIL I ST I KENNZIFFER I BEMERKUNGEN I

I TAFEL

GEN	TAFEL 19	FRONT - VERKLEIDUNGSELEMENTE	SPALTE 5C	ABB. BENENNUNG	ERSATZTEIL	ST	KENNZIFFER	BEMERKUNGEN	TAFEL
				1 PLAETTCHEN	254485	4	1550,551,555, 1552,553,557, 1556,558,		
				2 SCHRAUBE	257404	3	1550,551,555, 1552,553,557, 1556,558,		
				3 SCHEINWERFER-ABSCHL.-VERKLEID.	257415	1	1550,551,555, 1556,		
				3 SCHEINWERFER-ABSCHL.-VERKLEID. GRAUBLAU	296482	1	1552,553,557, 1558,	IA: AB APRIL 94	
				3 SCHEINWERFER-ABSCHL.-VERKLEID. GRAU	296524	1	1552,554,557, 1558,		
				4 PLAETTCHEN	184142	8	1550,551,555, 1552,553,557, 1556,558,		
				5 SCHRAUBE	258249	8	1550,551,555, 1552,553,557, 1556,558,		
				6 BEINSCHILD-VERKLEIDUNGSTEIL	922100	1	1550,551,555, 1552,553,557, 1556,558,		
				7 STEUERROHRSCHUTZ	910600	1	1550,551,555, 1552,553,557, 1556,558,		
				8 SCHRAUBE	258248	1	1550,551,552, 1553,		
				8 SCHRAUBE	257403	1	1555,556,557, 1558,		
				9 PIAGGIO-PLAKETTE	295486	1	1550,551,555, 1552,553,557, 1556,558,		
				10 U-SCHEIBE	003056	1	1555,556,557, 1558,		
				SCHRIFTZUG "PIAGGIO"	297159	1	1552,553,557, 1558,	IB: F. FZ-FARBE WEISS,GRUEN, GRAU	
				SCHRIFTZUG "PIAGGIO"	297160	1	1552,553,557, 1558,	IC: F. FZ-FARBE ROT,BLAU, VIOLA	

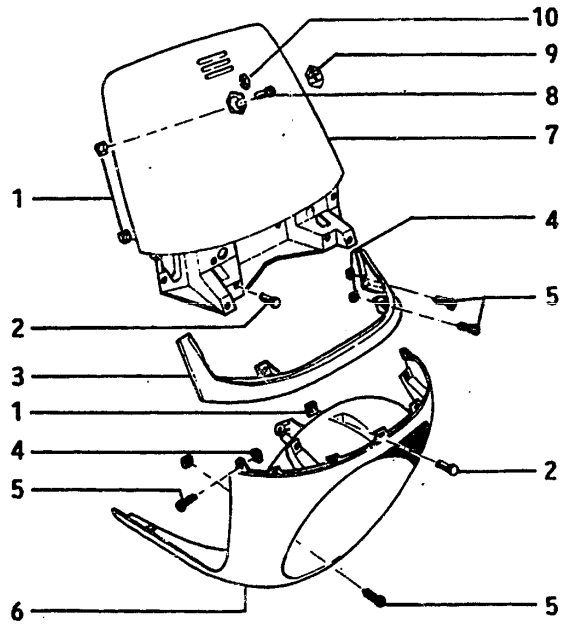

EN	TAFEL 20	GEPAECKFACH	SPALTE 5D	ABB. BENENNUNG	ERSATZTEIL	ST	IKENNZIFFER	IBEMERKUNGEN	TAFEL
B. 2-4				1 GEPAECKFACHEINHEIT KPL.	257803	A	1 1550,551,555, 1556,	IA: MIT ABB. 2-6, 9,14,15.	
I 1991				1 GEPAECKFACHEINHEIT, GRAUBLAU	296491	AB	1 1552,553,557, 1558,	IB: AB APRIL 94	
				1 GEPAECKFACHEINHEIT, GRAU	296527	AB	1 1552,553,557, 1558,		
				2 FEDER	257617		1 1550,551,555, 1552,553,557 1556,558,		
				3 GEPAECKFACHRIEGEL	295528		1 1550,551,555, 1552,553,557 1556,558,		
				4 DICHTUNG	257616		1 1550,551,555, 1552,553,557 1556,558,		
				5 SCHRAUBE	257613		2 1550,551,555, 1552,553,557 1556,558,		
				6 HALTER	252420		1 1550,551,555, 1552,553,557 1556,558,		
				7 PLAKETTE "S 50"	257836		1 1550,551,		
				7 PLAKETTE "S 50"	296503	C	1 1552,553,	IC: AB APRIL 94	
				7 PLAKETTE "S 50"	296547	D	1 1552,553,	FUER FZ-FARBEI GRAU, BLAU, VIOLA.	
				7 PLAKETTE "S 80"	259102		1 1555,556,		
				7 PLAKETTE "S 80"	296587	D	1 1557,558,	ID: AB APRIL 94,	
				7 PLAKETTE "S 80"	296586	C	1 1557,558,	FUER FZ-FARBEI GRUEN, ROT, WEISS.	
				8 SCHRAUBE	258249		4 1550,551,555, 1552,553,557, 1556,558,		
				9 PLAETTCHEN	184142		6 1550,551,555, 1552,553,557 1556,558,		
				10 FUSSRAUMABDECKUNG	257341		1 1550,551,555, 1556,		
				10 FUSSRAUMABDECKUNG GRAUBLAU	296484	B	1 1552,553,557, 1558,		
				10 FUSSRAUMABDECKUNG GRAU	258732	B	1 1552,553,557, 1558,		
				11 FEDERKLAMMER	254485		5 1550,551,555, 1552,553,557 1556,558,		
				12 U-SCHEIBE	003056		4 1550,551,555, 1552,553,557 1556,558,		

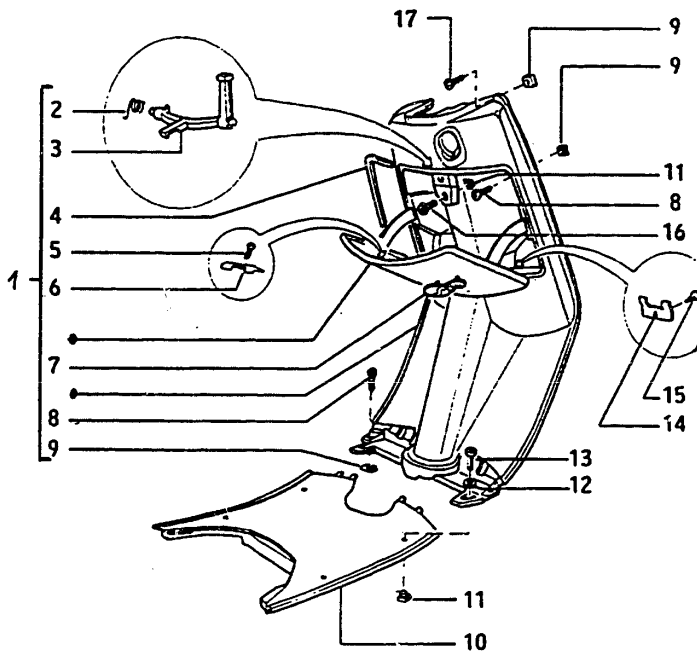

EN MIT
3E
290833
EN.

N	TAFEL 20	GEPAECKFACH	SPALTE 5E	ABB. BENENNUNG	ERSATZTEIL	ST	IKENNZIFFER	IBEMERKUNGEN	TAFEL
---	----------	-------------	-----------	----------------	------------	----	-------------	--------------	-------

N	TAFEL 20	GEPAECKFACH	SPALTE 5E	ABB. BENENNUNG	ERSATZTEIL	ST IKENNZIFFER	BEMERKUNGEN
				13 SCHRAUBE	257403	4 1550,551,555, 1552,553,557 1556,558,	
				14 HALTER	257614	2 1550,551,555, 1552,553,557 1556,558,	
				15 SCHRAUBE	257613	2 1550,551,555, 1552,553,557 1556,558,	
				16 SCHRAUBE	257404	1 1550,551,555, 1552,553,557 1556,558,	
				17 SCHRAUBE	257405	2 1550,551,555, 1552,553,557 1556,558,	

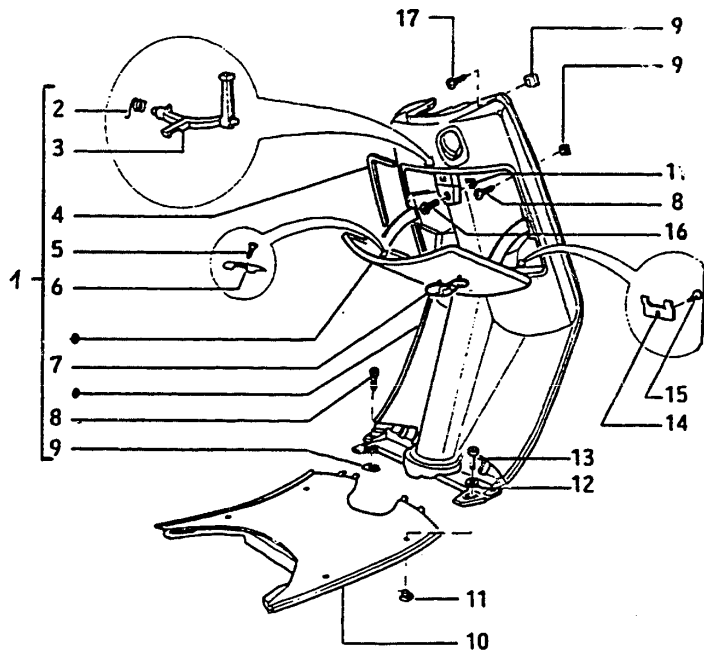

TAFEL 21

OELTANK

SPALTE 6A

ABB. BENENNUNG

ERSATZTEIL

ST IKENNZIFFER

BEMERKUNGEN

TAFEL

3



ABB. BENENNUNG	ERSATZTEIL	ST	IKENNZIFFER	BEMERKUNGEN
1 OELTANKVERSCHLUSS	218677	1	1550,551,555, 1552,553,557 1556,558,	
2 DICHTUNG	257538	1	1550,551,555, 1552,553,557 1556,558,	
3 OELTANK	258479	1	1550,551,555, 1556,	
3 OELTANK	259952	1	1552,553,557, 1558,	IB: AB APRIL 94
4 SCHRAUBE	257404	2	1550,551,555, 1552,553,557 1556,558,	
5 SCHELLE	256074	1	1550,551,555, 1552,553,557 1556,558,	
6 DICHTUNG	196868	1	1550,551,555, 1552,553,557 1556,558,	
7 ANSCHLUSSTUTZEN	197572	1	1550,551,555, 1552,553,557 1556,558,	
8 SCHELLE	104296	1	1550,551,555, 1552,553,557 1556,558,	
9 OELSTANDSANZEIGER	290761	1	1550,555,	
9 OELSTANDSANZEIGER	292596	1	1550,551,555, 1556,	IA: AB APRIL 93
9 OELSTANDSANZEIGER	292380	1	1552,553,557, 1558,	

ITAFEL 22 BENZINTANK

SPALTE 6B

ITAFEL I ABB. BENENNUNG I ERSATZTEIL I ST I KENNZIFFER I BEMERKUNGEN I

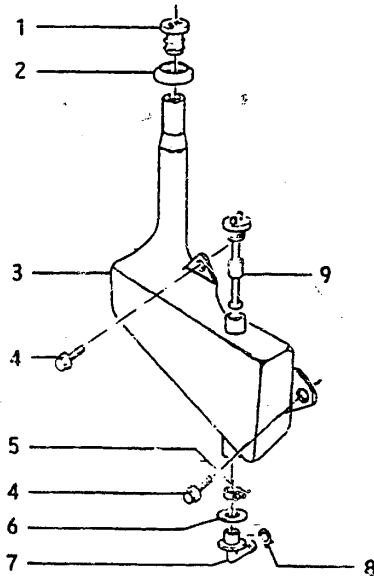
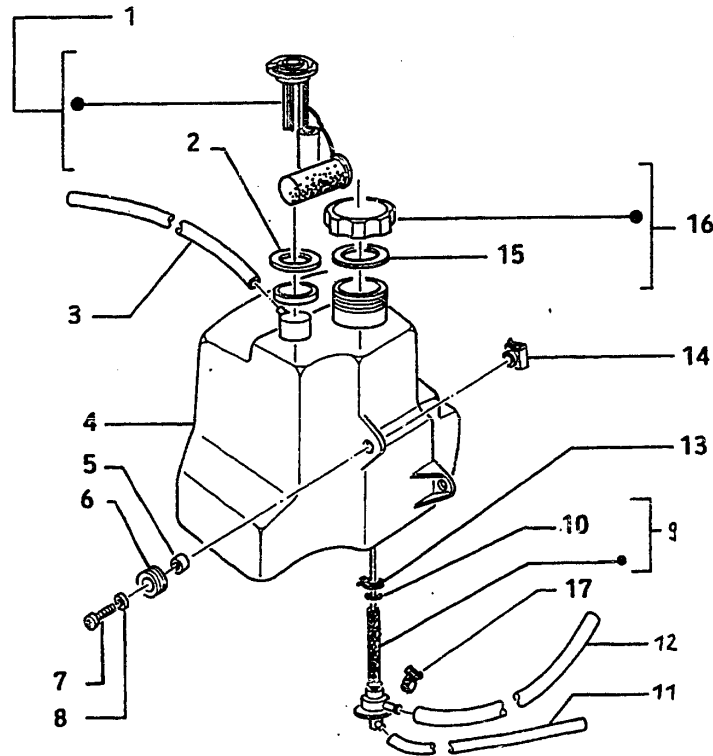

ITAFEL	ABB. BENENNUNG	ERSATZTEIL	ST	KENNZIFFER	BEMERKUNGEN
I	I 1 BENZINSTANDSANZEIGER	I 257303	I 1	I 1550,555,	I IA: MIT ABB. 2
I	I	I A	I	I	I
I	I 1 BENZINSTANDSANZEIGER	I 259442	I 1	I 1550,551,555,	I IF: AB FG-NR.:
I	I	I F	I	I 1552,553,557,	I NSLIT 78454
I	I	I F	I	I 1556,558,	I NS81T 16624
I	I 2 DICHTUNG	I 258161	I 1	I 1550,551,555,	I
I	I	I	I	I 1552,553,557	I
I	I	I	I	I 1556,558,	I
I	I 3 ENTLUEFTUNGSSCHLAUCH	I 252832	I 1	I 1550,551,	I
I	I	I	I	I 1552,553,	I
I	I	I	I	I	I
I	I 3 ENTLUEFTUNGSSCHLAUCH	I 219379	I 1	I 1555,556,557,	I
I	I	I	I	I 1558,	I
I	I	I	I	I	I
I	I 4 BENZINTANK	I 257264	I 1	I 1550,	I
I	I	I	I	I	I
I	I 4 BENZINTANK	I 259107	I 1	I 1550,555,	I
I	I	I	I	I	I
I	I 4 BENZINTANK	I 259403	I 1	I 1550,551,555,	I
I	I	I F	I	I 1556,	I
I	I 4 BENZINTANK	I 296614	I 1	I 1552,553,557,	I ID: AB APRIL 94
I	I	I D	I	I 1558,	I
I	I 5 DISTANZSTUECK	I 257302	I 3	I 1550,555,	I
I	I	I	I	I	I
I	I 5 DISTANZSTUECK	I 257302	I 2	I 1550,551,555,	I
I	I	I F	I	I 1552,553,557,	I
I	I	I	I	I 1556,558,	I
I	I 6 SCHEIBE	I 257301	I 3	I 1550,555,	I
I	I	I	I	I	I
I	I 6 SCHEIBE	I 257301	I 2	I 1550,551,555,	I
I	I	I F	I	I 1552,553,557,	I
I	I	I	I	I 1556,558,	I
I	I 7 SCHRAUBE	I 257403	I 3	I 1550,555,	I
I	I	I	I	I	I
I	I 7 SCHRAUBE	I 257403	I 2	I 1550,551,555,	I
I	I	I F	I	I 1552,553,557,	I
I	I	I	I	I 1556,558,	I
I	I 7 SCHRAUBE	I 015558	I 1	I 1550,551,555,	I
I	I	I F	I	I 1552,553,557,	I
I	I	I	I	I 1556,558,	I
I	I 8 U-SCHEIBE	I 179575	I 3	I 1550,555,	I
I	I	I	I	I	I
I	I 8 U-SCHEIBE	I 179575	I 2	I 1550,551,555,	I
I	I	I F	I	I 1552,553,557,	I
I	I	I	I	I 1556,558,	I
I	I 9 BENZINHAHN	I 295311	I 1	I 1550,551,555,	I IB: MIT ABB. 10
I	I	I B	I	I 1556,	I
I	I 9 BENZINHAHN	I 295534	I 1	I 1552,553,557,	I
I	I	I D	I	I 1558,	I
I	I	I	I	I	I
I	I 10 DICHTUNG	I 196868	I 1	I 1550,551,555,	I
I	I	I	I	I 1552,553,557	I
I	I	I	I	I 1556,558,	I
I	I 11 UNTERDR. SCHLAUCH	I 257817	I 1	I 1550,551,555,	I
I	I	I	I	I 1552,553,557	I
I	I	I	I	I 1556,558,	I

ITAFEL 22 BENZINTANK

SPALTE 6C

ITAFEL I ABB. BENENNUNG

I ERSATZTEIL

I ST I KENNZIFFER

I BEMERKUNGEN

ITAFEL

IN	TAFEL 22	BENZINTANK	SPALTE 6C	I ABB. BENENNUNG	I ERSATZTEIL	I ST IKENNZIFFER	I BEMERKUNGEN	I TAFEL
				12 BENZINSCHLAUCH	137679	1 1550,551,555, 1552,553,557		
				13 SCHELLE	256074	1 1550,551,555, 1552,553,557 1556,558,		
				14 FEDERKLAMMER	254485	3 1550,551,555, 1552,553,557 1556,558,		
				15 DICHUNG	258160	1 1550,551,555, 1552,553,557 1556,558,		
				16 BENZINTANK- VERSCHLUSS	255100	1 1550,552,555, 1557,	IC: MIT ABB. 15	
				16 BENZINTANK- VERSCHLUSS	295598	1 1551,553,556, 1558,		
				17 SCHELLE	194011	1 1555,556,557, 1556,		
				KABELDURCHGANG	307166	1 1550,551,555, 1552,553,557, 1556,558,	IE: AB OKTOBER 91	

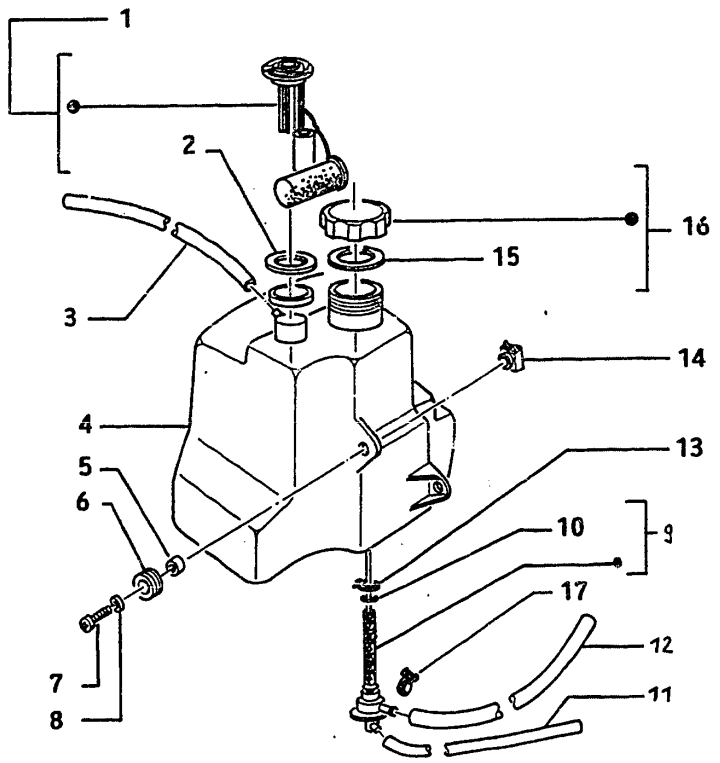

L 94

ARBE
RUEN,

ARBE
U,

IN	TAFEL 23	HELMFACH	SPALTE 6D	I ABB. BENENNUNG	I ERSATZTEIL	I ST IKENNZIFFER	I BEMERKUNGEN	I TAFEL
----	----------	----------	-----------	------------------	--------------	------------------	---------------	---------



ABB. BENENNUNG	ERSATZTEIL	ST	IKENNZIFFER	BEMERKUNGEN
1 SCHRAUBE	258249	4	1550,551,555, 1552,553,557, 1556,558,	
2 HUELSE	258788	2	1550,551,555, 1552,553,557, 1556,558,	
3 VERBINDUNGSTEIL	911000	1	1550,551,555, 1555,	
3 VERBINDUNGSTEIL	928000	1	1552,553,557, 1558,	IF: AB APRIL 94
4 FEDER	257533	1	1550,551,555, 1552,553,557, 1556,558,	
5 SPLINT	008808	1	1550,551,555, 1552,553,557, 1556,558,	
6 SITZBANKRIEGEL	257532	1	1550,551,555, 1552,553,557, 1556,558,	
7 SCHRAUBE	257404	7	1550,551,555, 1552,553,557, 1556,558,	
8 PLAETTCHEN	184142	6	1550,551,555, 1552,553,557, 1556,558,	
9 PLAKETTE "SFERA"	257867	1	1550,551,555, 1556,	
9 PLAKETTE "SFERA"	296501	1	1552,553,557, 1558,	IF: AB APRIL 94
9 PLAKETTE "SFERA"	296544	1	1552,553,557, 1558,	FUER FZ-FARBE GRAU, BLAU, VIOLA.
10 PLAKETTE "S 50" (LINKS)	257832	1	1550,	
10 PLAKETTE "KAT"	259040	1	1551,556,	IG: AB APRIL 94,
10 PLAKETTE "S 80" (LINKS)	259103	1	1555,	F. FZ-FARBE GRUEN, ROT, WEISS.
10 PLAKETTE "S 50" (RECHTS)	257833	1	1550,551,	
10 PLAKETTE "S 80" (RECHTS)	258524	1	1555,556,	
11 PLAETTCHEN	254485	7	1550,551,555, 1552,553,557, 1556,558,	
12 SEITENVERKLEIDUNG LINKS	916000	1	1550,	
12 SEITENVERKLEIDUNG LINKS	916200	1	1550,551,555, 1552,553,557, 1556,558,	IB: M.ABB.8,14,15
13 SITZBANKUNTERTEIL	257897	1	1550,555,	IA: FUER MODELL 550: AB FG-NRI NSLIT 0036260

15
ER 91

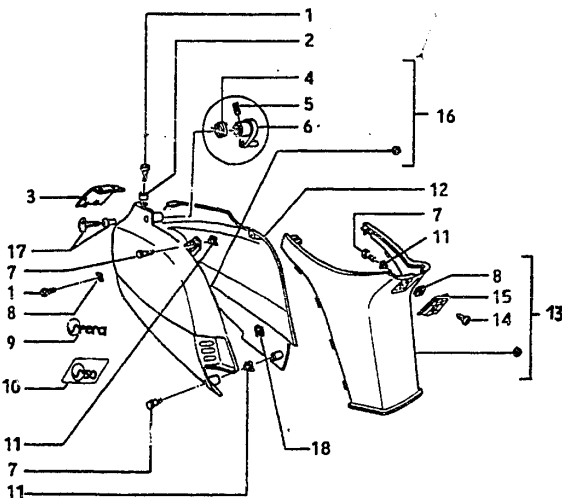

ABB. BENENNUNG	ERSATZTEIL	ST	IKENNZIFFER	IBEMERKUNGEN
FEDERRING	016408	3	1550,551,555,	
	A		1552,553,557,	
			1556,558,	
MUTTER	020108	2	1550,551,555,	
	A		1552,553,557,	
			1556,558,	
ABZIEHBUSSDERSATZ TUERKIS FUER SONDERMODELL	259992	1	1550,	

TAFEL 24
8

TAFEL 25

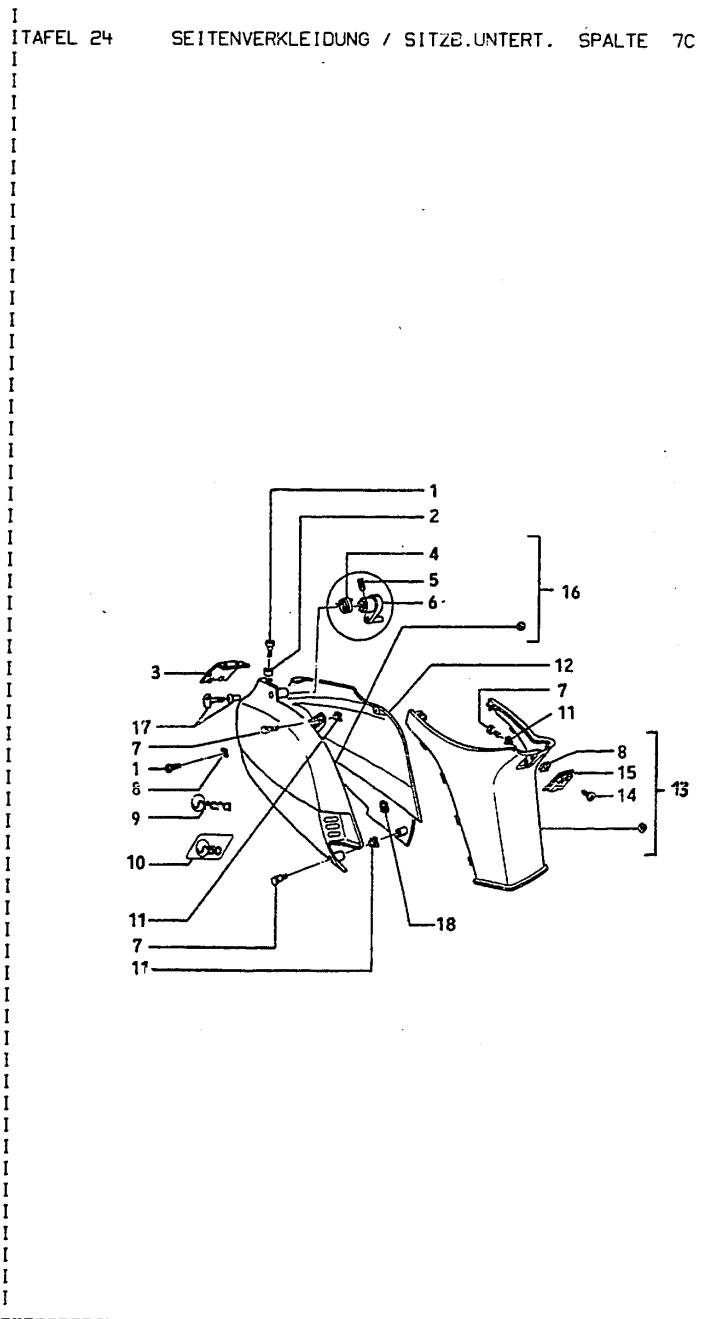

ABB. BENENNUNG	ERSATZTEIL	ST	IKENNZIFFER	IBEMERKUNGEN
FEDERKLAMMER	254495	2	1550,551,555,	

TAFEL 25

TAFEL 25 VORDERRAD- U. HINTERRADKOTFLUEGEL SPALTE 7D		ABB. BENENNUNG	ERSATZTEIL	ST	IKENNZIFFER	BEMERKUNGEN	TAFEL 29
		1 FEDERKLAMMER	254485	2	1550,551,555, 1552,553,557, 1556,558,		
		2 SCHRAUBE	030054	1	1550,551,555, 1552,553,557, 1556,558,		
		3 U-SCHEIBE	013880	2	1550,551,555, 1552,553,557, 1556,558,		
1545		4 U-SCHEIBE	012533	2	1550,551,555, 1552,553,557, 1556,558,		
		5 HINTERRAD- KOTFLUEGEL	257272	1	1550,555,		
		5 HINTERRAD- KOTFLUEGEL	258235	1	1550,555,	IA: AB FG-NR.: NSLIT 36685 NS81T 2990	
2-5,		5 HINTERRAD- KOTFLUEGEL	295531	1	1550,551,555, 1552,553,557, 1556,558,	IB: AB FEB. 93	
94		6 SCHRAUBE	257403	1	1550,551,555, 1552,553,557, 1556,558,		
		7 SCHRAUBE	031092	3	1550,551,555, 1552,553,557, 1556,558,		
28		8 U-SCHEIBE	013880	3	1550,551,555, 1552,553,557, 1556,558,		
		9 SCHRAUBE	031087	1	1550,551,555, 1552,553,557, 1556,558,		
		10 FEDERRING	016406	5	1550,551,555, 1552,553,557, 1556,558,		
		11 U-SCHEIBE	013777	2	1550,551,555, 1552,553,557, 1556,558,		
		12 FEDER	266860	1	1550,551,555, 1552,553,557, 1556,558,		
		13 MUTTER	251875	2	1550,551,555, 1552,553,557, 1556,558,		
		14 VORDERRAD- KOTFLUEGEL	910500	1	1550,551,555, 1552,553,557, 1556,558,		
		15 MUTTER	020106	3	1550,551,555, 1552,553,557, 1556,558,		
		16 U-SCHEIBE	003056	1	1550,551,555, 1552,553,557, 1556,558,		

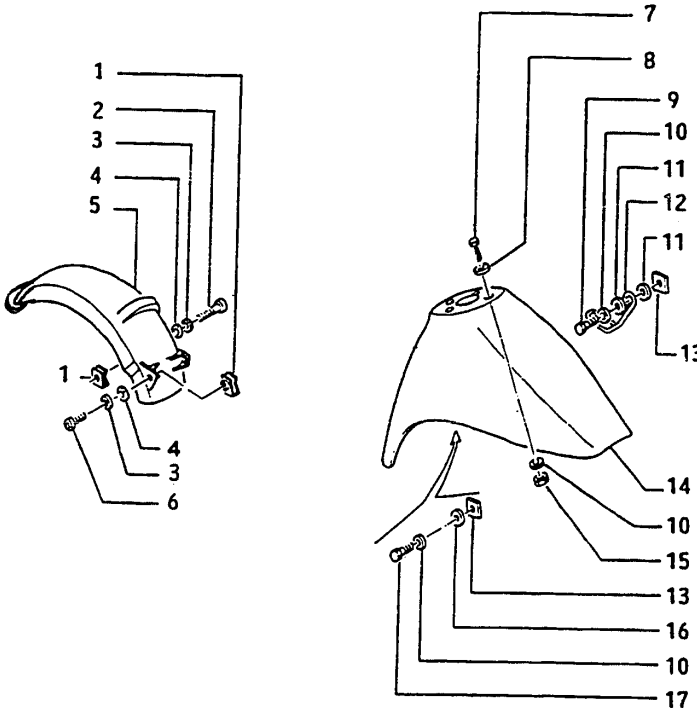

TAFEL 25 VORDERRAD- U. HINTERRADKOTFLUEGEL SPALTE 7E		ABB. BENENNUNG	ERSATZTEIL	ST	IKENNZIFFER	BEMERKUNGEN
		17 SCHRAUBE	031086	1	1550,551,555,	



ABB. BENENNUNG	ERSATZTEIL	ST	IKENNZIFFER	BEMERKUNGEN
1 SITZBANK	267243	1	1550,551,555,	IA: MIT ABB. 2
	A		1556,	
1 SITZBANK	296855	1	1552,553,557,	
	AC		1558,	IC: AB APRIL 94
1 SITZBANK, TUERKISI	270830	1	1550,	
	AB			IB: SONDERMODELL
2 SCHRAUBE	265808	2	1550,551,555,	
			1552,553,557,	
			1556,558,	
3 SCHRAUBE	031088	2	1550,551,555,	
			1552,553,557,	
			1556,558,	
4 SCHRAUBE	031088	2	1550,551,555,	
			1552,553,557,	
			1556,558,	
5 FEDERRING	016406	2	1550,551,555,	
			1552,553,557,	
			1556,558,	
6 SITZBANKVER- SCHLUSS	268300	1	1550,551,555,	
			1552,553,557,	
			1556,558,	
7 FEDERRING	016406	2	1550,551,555,	
			1552,553,557,	
			1556,558,	
8 BEIFAHRERHALTE- GRIFF-SATZ	437798	1	1550,551,555,	
			1556,	
9 GEPAECKTRAEGER	296496	1	1552,553,557,	
	C		1558,	
10 SCHRAUBE	257404	2	1552,553,557,	
	C		1558,	
11 IMBUSSCHRAUBE	296659	1	1552,553,557,	
	C		1558,	
12 SCHEIBE	296748	1	1552,553,557,	
	C		1558,	
13 BUCHSE	296585	1	1552,553,557,	
	C		1558,	

ABB. BENENNUNG	ERSATZTEIL	ST	KENNZIFFER	BEMERKUNGEN
1 LAGERSATZ	153025	1	1550,551,555, 1552,553,557, 1556,558,	IA: MIT ABB. 3-7
2 LAGERSATZ	153024	1	1550,551,555, 1552,553,557, 1556,558,	IB: MIT ABB. 8-11
3 OBERER FESTSTELLRING	011109	1	1550,551,555, 1552,553,557, 1556,558,	
4 NASENSCHEIBE	003751	1	1550,551,555, 1552,553,557, 1556,558,	
5 LAGERSCHALE	055986	1	1550,551,555, 1552,553,557, 1556,558,	
6 KUGELKRANZ	077024	1	1550,551,555, 1552,553,557, 1556,558,	
7 LAGERSATZ	056641	1	1550,551,555, 1552,553,557, 1556,558,	
8 STEUERLAGER	092667	1	1550,551,555, 1552,553,557, 1556,558,	
9 KUGELKRANZ	077023	1	1550,551,555, 1552,553,557, 1556,558,	
10 LAGERSCHALE	055989	1	1550,551,555, 1552,553,557, 1556,558,	
11 SCHUTZRING	019264	1	1550,551,555, 1552,553,557, 1556,558,	
12 MUTTER	020106	1	1550,551,555, 1552,553,557, 1556,558,	
13 FEDERRING	016406	1	1550,551,555, 1552,553,557, 1556,558,	
14 U-SCHEIBE	003056	2	1550,551,555, 1552,553,557, 1556,558,	
15 VORDERRAD-SCHWINGENVERKLEIDUNG	266829	1	1550,555,	
15 VORDERRAD-SCHWINGENVERKLEIDUNG	269673	1	1550,551,555, 1556,	IC: AB FG-NR.: NSL1T 78454 NS81T 16624
15 VORDERRAD-SCHWINGENVERKLEIDUNG	273075	1	1552,553,557, 1558,	ID: AB APRIL 94
16 SCHRAUBE	015759	1	1550,551,555, 1552,553,557, 1556,558,	

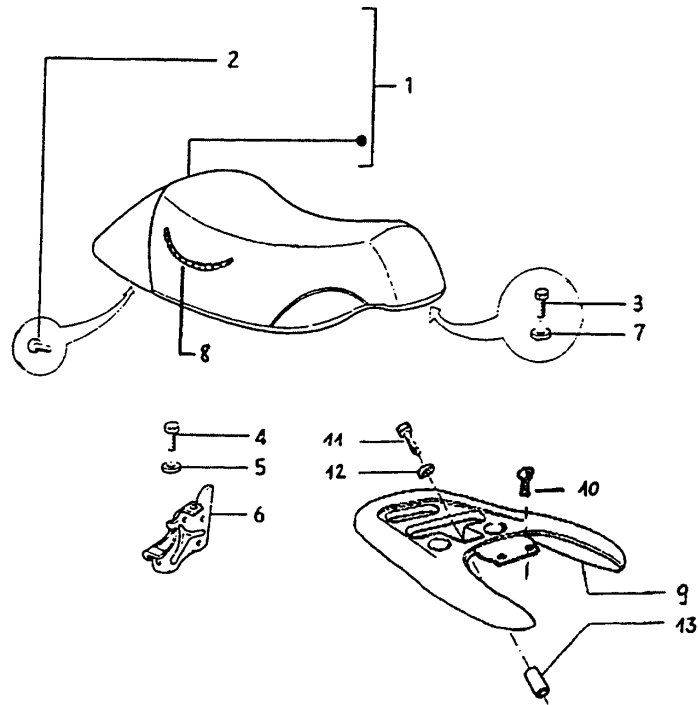
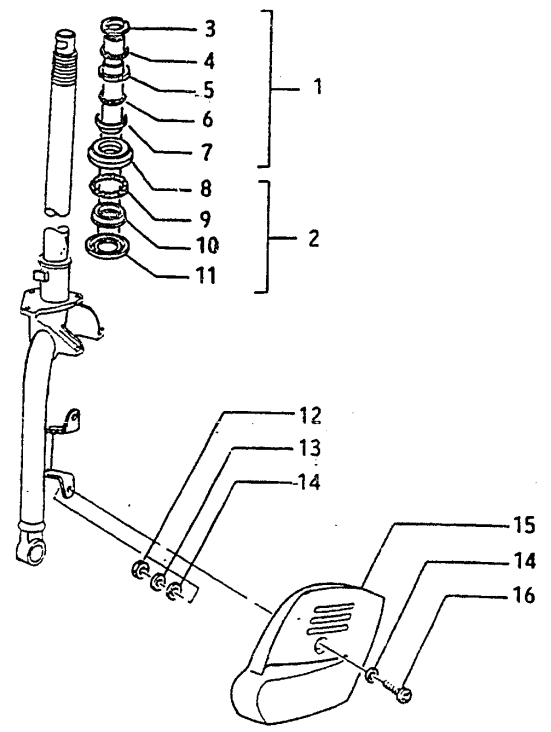

BEI

151

NR 501

ABB. BENENNUNG	ERSATZTEIL	ST	KENNZIFFER	BEMERKUNGEN
----------------	------------	----	------------	-------------

TAFEL 28		STEUERROHR - VORDERRADSCHWINGE		SPALTE 9B		I ABB. BENENNUNG		I ERSATZTEIL I ST IKENNZIFFER		I BEMERKUNGEN		TAFEL 3	
151						1	SCHRAUBE	031056	1	1550,551,555,			
										1552,553,557			
										1556,558,			
3E1						2	FEDERRING	016405	1	1550,551,555,			
										1552,553,557			
										1556,558,			
						3	PLAETTCHEN	177671	1	1550,551,555,			
										1552,553,557			
										1556,558,			
3E1						4	PUFFER	266841	1	1550,551,555,			
										1552,553,557			
										1556,558,			
						5	HALTER	266840	1	1550,551,555,			
										1552,553,557			
										1556,558,			
3						6	TACHORITZEL	267189	1	1550,551,555,			
										1552,553,557			
										1556,558,			
						7	DICHTRING	177432	1	1550,551,555,			
										1552,553,557			
										1556,558,			
						8	ZAHNKRANZ	266854	1	1550,551,555,			
										1552,553,557			
										1556,558,			
101						9	SCHULTERRING	266940	1	1550,551,555,			
										1552,553,557			
										1556,558,			
						10	ROLLENKAEFIG	177436	2	1550,551,555,			
										1552,553,557			
										1556,558,			
						11	BREMSANKERPLATTE	266831	1	1550,551,555,			
										1552,553,557			
										1556,558,			
						12	DICHTRING	177521	1	1550,551,555,			
										1552,553,557			
										1556,558,			
						13	DISTANZSCHEIBE	177445	1	1550,551,555,			
										1552,553,557			
										1556,558,			
						14	SPRENGRING	177408	1	1550,551,555,			
										1552,553,557			
										1556,558,			
						15	ROLLENKAEFIG	198513	2	1550,551,555,			
										1552,553,557			
										1556,558,			
						16	DICHTRING	119219	2	1550,551,555,			
										1552,553,557			
										1556,558,			
RI						17	BOLZEN	177451	1	1550,551,555,			
OI										1552,553,557			
										1556,558,			
						18	VORDERRADSCHWINGE	266698	1	1550,551,555,			
										1552,553,557			
										1556,558,			
						19	DICHTUNG	006731	2	1550,551,555,			
										1552,553,557			
										1556,558,			

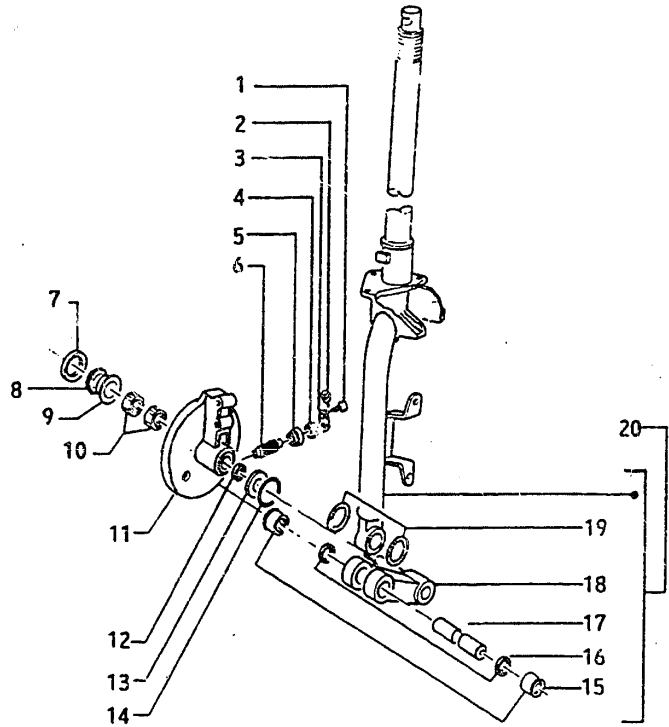

TAFEL 28		STEUERROHR - VORDERRADSCHWINGE		SPALTE 8C		I ABB. BENENNUNG		I ERSATZTEIL I ST IKENNZIFFER		I BEMERKUNGEN		TAFEL 3	
----------	--	--------------------------------	--	-----------	--	------------------	--	-------------------------------	--	---------------	--	---------	--

TAFEL 28 STEUEROHR - VORDERRADSWINGE SPALTE 8C

ABB. BENENNUNG I ERSATZTEIL I ST IKENNZIFFER IBEMERKUNGEN

20 STEUEROHR KPL.	266826	1	1550,551,555,	IA: MIT ABB.15-19
			1552,553,557	
	A		1556,558,	

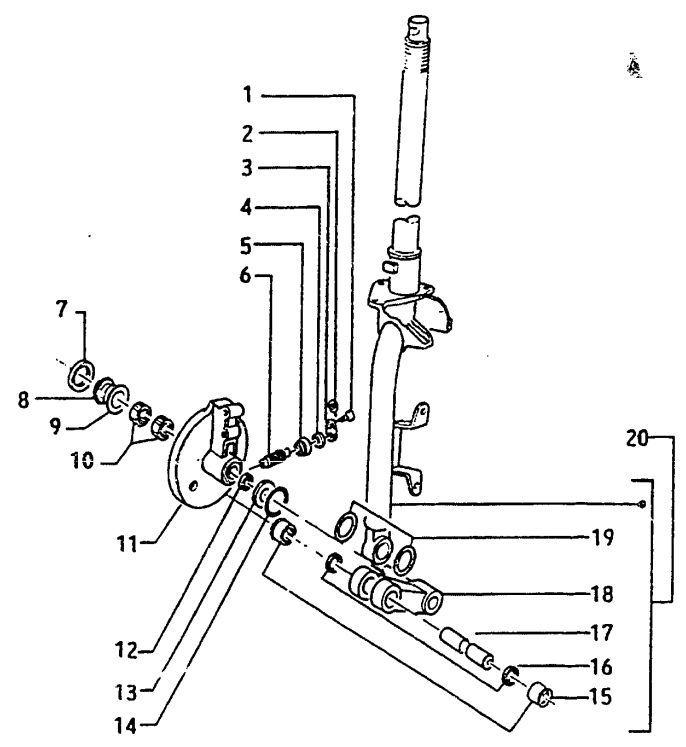

TAFEL 29 VORDERRADBREMSE SPALTE 8D

ABB. BENENNUNG I ERSATZTEIL I ST IKENNZIFFER IBEMERKUNGEN

TAFEL 29 VORDERRADBREMSE

SPALTE 8D

IBB. BENENNUNG	ERSATZTEIL	ST	IKENNZIFFER	IBEMERKUNGEN
1 FEDER	266725	2	1550,555,	IB: AB MOTOR-NR.: I
1 FEDER	269293	2	1550,555,	NSL1M 32155 I
1 FEDER	266725	2	1550,551,555,	NS81M 2060 I
2 SPLINT	012789	1	1550,551,555,	IC: AB MOTOR-NR.: I
3 U-SCHEIBE	266845	1	1550,551,555,	NSL1M 34825 I
4 MUTTER	219397	1	1550,551,555,	NS81M 4095 I
5 ABDECKKAPPE	177609	1	1550,551,555,	
6 BREMSNOCKEN	266835	1	1550,551,555,	
7 BREMSBACKENSCHUH	266724	2	1550,551,555,	
8 BREMSBACKENSATZ	267602	2	1550,551,555,	IA: MIT ABB. 7 I
9 BREMSHEBEL	266694	1	1550,551,555,	
10 U-SCHEIBE	179575	1	1550,551,555,	
11 FEDERRING	016406	1	1550,551,555,	
12 MUTTER	020106	1	1550,551,555,	

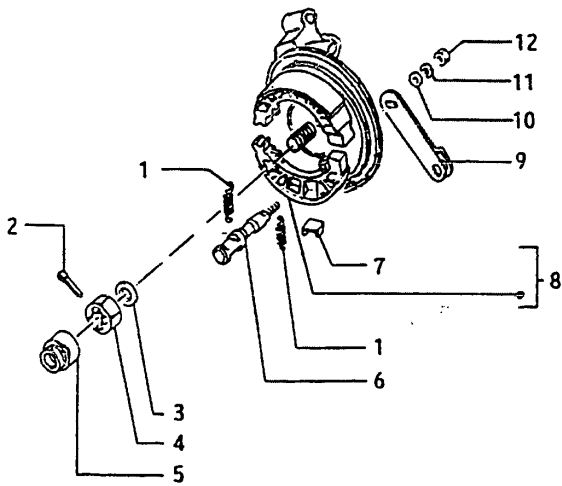

85
90
3

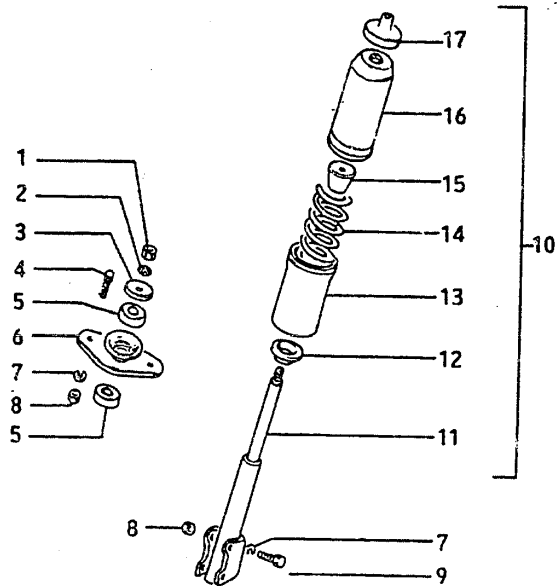

I ABB. BENENNUNG	I ERSATZTEIL	I ST IKENNZIFFER	I BEMERKUNGEN
1 MUTTER	021210	1 1550,551,555, 1552,553,557 1556,558,	
2 FEDERRING	016410	1 1550,551,555, 1552,553,557 1556,558,	
3 SCHEIBE	174088	1 1550,551,555, 1552,553,557 1556,558,	
4 SCHRAUBE	031119	2 1550,551,555, 1552,553,557 1556,558,	
5 PUFFER	216209	2 1550,551,555, 1552,553,557 1556,558,	
6 HALTER	225748	1 1550,551,555, 1552,553,557 1556,558,	
7 FEDERRING	016408	4 1550,551,555, 1552,553,557 1556,558,	
8 MUTTER	020108	4 1550,551,555, 1552,553,557 1556,558,	
9 SCHRAUBE	030074	2 1550,551,555, 1552,553,557 1556,558,	
10 VORDERER STOSS- DAEMPFER KPL.	267074	1 1550,551,555, 1552,553,557, 1556,558,	IA: MIT ABB.11-171
11 STOSSDAEMPFER- INNENROHR	266539	1 1550,551,555, 1552,553,557, 1556,558,	
12 FEDERTELLER	225743	1 1550,551,555, 1552,553,557 1556,558,	
13 AUSSERES STOSS- DAEMPFERROHR	267075	1 1550,551,555, 1552,553,557, 1556,558,	
14 STOSSDAEMPFER- FEDER	266518	1 1550,551,555, 1552,553,557, 1556,558,	
15 PUFFER	216233	1 1550,551,555, 1552,553,557 1556,558,	
16 STOSSDAEMPFER- ABDECKUNG	267076	1 1550,551,555, 1552,553,557, 1556,558,	
17 OBERE PLATTE	216234	1 1550,551,555, 1552,553,557 1556,558,	

TAFEL 31 STOSSDAEMPFER - HINTEN

SPALTE 9B



ABB. BENENNUNG	ERSATZTEIL	ST	IKENNZIFFER	BEMERKUNGEN
1 MUTTER	021108	2	1550,551,555, 1552,553,557 1556,558,	
2 GUMMIPUFFER	178149	1	1550,551,555, 1552,553,557 1556,558,	
3 STOSSDAEMPFERROHRE	267033	1	1550, 1556,558,	
3 STOSSDAEMPFERROHRE	268705	1	1550,551,555, 1552,553,557, 1556,558,	IA: FUER MODELL 550: AB FG-NRI NSLIT 19147
4 PUFFER	267032	1	1550, 1556,558,	
4 PUFFER	057894	1	1550,551,555, 1552,553,557, 1556,558,	
5 STOSSDAEMPFER	268698	1	1550,551,555, 1556,	
5 STOSSDAEMPFER	272939	1	1550,551,555, 1552,553,557, 1556,558,	IB: AB NOV. 93
6 STOSSDAEMPFER- FEDER	267633	1	1550,551,555, 1552,553,557, 1556,558,	
7 SCHRAUBBOLZEN	267158	1	1550,551,555, 1552,553,557 1556,558,	
8 MUTTER	232108	1	1550,551,555, 1552,553,557 1556,558,	
9 FEDERRING	003060	1	1550,551,555, 1552,553,557 1556,558,	
10 PUFFER	178150	1	1550,551,555, 1552,553,557 1556,558,	
11 U-SCHEIBE	267038	1	1550,551,555, 1552,553,557 1556,558,	
12 FEDERRING	016408	1	1550,551,555, 1552,553,557 1556,558,	
13 KAPPE	267034	1	1550, 1556,558,	
13 KAPPE	268706	1	1550,551,555, 1552,553,557, 1556,558,	

TAFEL 32

1
2
3
1
4
5
14
15

TAFEL 32

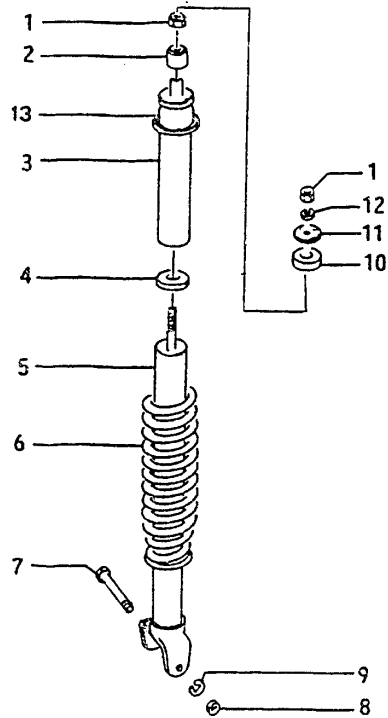
TACHOMETER / LENKERDECKEL

SPALTE 10A

I ABB. BENENNUNG

I ERSATZTEIL

I ST IKENNZIFFER

I BEMERKUNGEN

I TAFEL 35

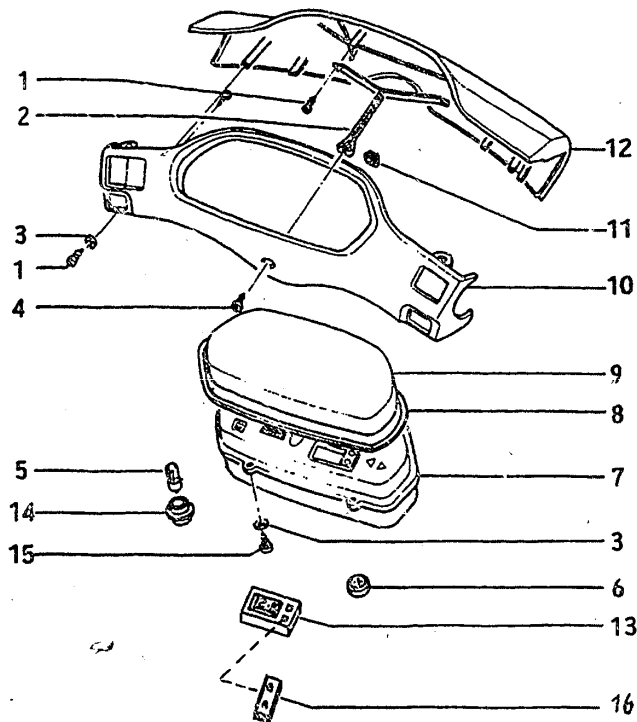

I ABB. BENENNUNG	I ERSATZTEIL	I ST IKENNZIFFER	I BEMERKUNGEN
1 SCHRAUBE	267115	7 1550,551,555, 1552,553,557 1556,558,	
2 HALTER	267144	1 1550,551,555, 1552,553,557 1556,558,	
3 U-SCHEIBE	013769	6 1550,551,555, 1552,553,557 1556,558,	
4 SCHRAUBE	258249	1 1550,551,555, 1552,553,557 1556,558,	
5 SOFITE 12V-1,2W	164634	8 1550,551,555, 1552,553,557 1556,558,	
6 KNOPFBATTERIE	498342	1 1550,551,555, 1552,553,557 1556,558,	
7 TACHOMETER	270303	1 1550,	IC: AB FG-NR.: NSL1T 91225
7 TACHOMETER	270300	1 1550,551,	
7 TACHOMETER	273039	1 1552,553,	IA: AB APRIL 94
7 TACHOMETER	267124	1 1555,	
7 TACHOMETER	270301	1 1555,556,	ID: AB FG-NR.: NS81T 16624
7 TACHOMETER	273071	1 1557,558,	
8 DICHTUNG	498341	1 1550,551,555, 1552,553,557 1556,558,	
9 TACHOMETER- ABDECKUNG	498340	1 1550,551,555, 1552,553,557, 1556,558,	
10 LENKERDECKEL- HAELFTE	267145	1 1550,551,555, 1556,	
10 LENKERDECKEL- HAELFTE GRAUBLAU	273045	1 1552,553,557, 1538,	IA: AB APRIL 94
10 LENKERDECKEL- HAELFTE	273048	1 1552,553,557, 1558,	
11 FEDERKLAMMER	255437	1 1550,551,555, 1552,553,557 1556,558,	
12 LENKERDECKEL- HAELFTE	915000	1 1550,551,555, 1552,553,557, 1556,558,	
13 UHR	498361	1 1550,551,555, 1552,553,557, 1556,558,	IB: MIT BATTERIE ET-NR: 498342
14 FASSUNG F. SOFITE	212128	8 1550,551,555, 1552,553,557 1555,558,	

-A 10 -

TAFEL 32

TACHOMETER / LENKERDECKEL

SPALTE 10B

I ABB. BENENNUNG

I ERSATZTEIL

I ST IKENNZIFFER

I BEMERKUNGEN

I TAFEL 36

TAFEL 32 TACHOMETER / LENKERDECKEL

SPALTE 10B

I ABB. BENENNUNG

I ERSATZTEIL I

I ST IKENNZIFFER

I BEMERKUNGEN

TAFEL 36

15	SCHRAUBE FUER TACHOMETERBEFEST.	265808	4	1550,551,555, 1552,553,557, 1556,558,
16	GUMMIPROPFEN F. UHR	498365	1	1550,551,555, 1552,553,557, 1556,558,

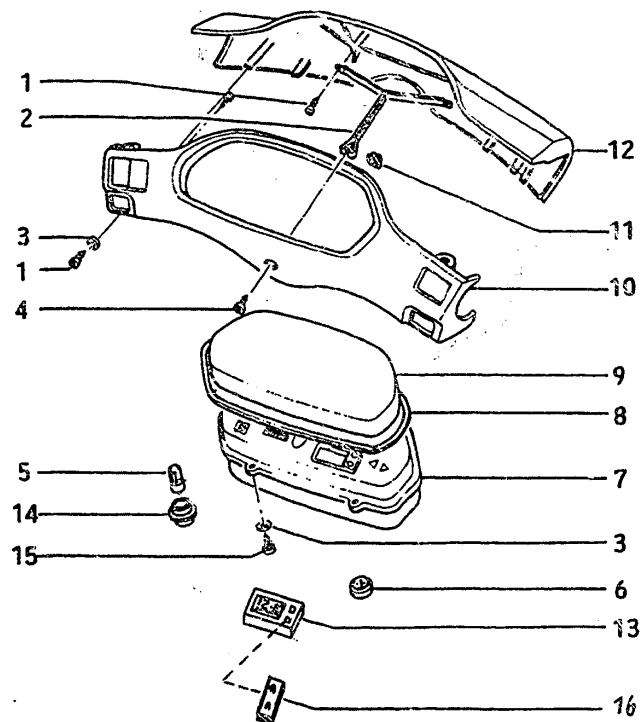

1

3

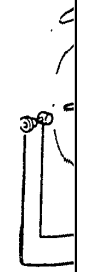

TAFEL 33

GASDREHGRIF / HANDBREMSHEBEL

SPALTE 10C

I ABB. BENENNUNG

I ERSATZTEIL I

I ST IKENNZIFFER

I BEMERKUNGEN

I

TAFEL 33		GASDREHGRIFF / HANDBREMSHEBEL		SPALTE 10C		I ABB. BENENNUNG		I ERSATZTEIL I ST I KENNZIFFER		I BEMERKUNGEN	
	1	GASDREHGRIFF KPL.	271189	1	1550,551,555, 1556,	IA: MIT ABB. 2-10;					
	1	GASDREHGRIFF KPL.	272401	1	1550,551,555, 1552,553,557, 1556,558,	IB: AB FG-NR.: NSL1T 125945					
	2	SCHRAUBE M. MUTTER	265249	1	1550,351,555, 1552,553,557						
	3	FEDER	177072	1	1550,551,555, 1552,553,557						
	4	SCHRAUBE MIT DISTANZRING	123394	1	1550,551,555, 1552,553,557, 1556,558,						
	5	GUMMIGRIFF	271181	1	1550,551,555, 1552,553,557						
	6	GLEITAUFLAGE	229935	1	1550,551,555, 1552,553,557						
	7	SCHRAUBE	123391	1	1550,551,555, 1552,553,557						
	8	VORDERRADHAND- BREMSHEBEL	267949	1	1550,551,555, 1552,553,557, 1556,558,						
	9	SCHRAUBE	123389	1	1550,551,555, 1552,553,557						
10	BREMSLICHT- SCHALTER	126899	1	1550,551,555, 1552,553,557, 1556,558,							
		RUECKSTELLFEDER F. GASDREHGRIFF	271174	1	1550,551,555, 1552,553,557, 1556,558,						

TAFEL 34		LENKER - HINTERRADHANDBREMSHEBEL		SPALTE 10D		I ABB. BENENNUNG		I ERSATZTEIL I ST I KENNZIFFER		I BEMERKUNGEN	
----------	--	----------------------------------	--	------------	--	------------------	--	--------------------------------	--	---------------	--

TAFEL 34 LENKER - HINTERRADHANDBREMSHEBEL SPALTE 10D



ABB. BENENNUNG	ERSATZTEIL	ST	KENNZIFFER	BEMERKUNGEN
1 RUECKSPIEGEL LINKS	267168	1	1550,551,555, 1552,553,557, 1556,558,	
1 RUECKSPIEGEL RECHTS	267169	1	1550,551,555, 1552,553,557, 1556,558,	
2 SCHRAUBE MIT DISTANZRING	123394	1	1550,551,555, 1552,553,557, 1556,558,	
3 FEDER	267948	1	1550,551,555, 1552,553,557 1556,558,	
4 SCHRAUBE M.MUTTER	265249	1	1550,551,555, 1552,553,557 1556,558,	
5 GUMMIGRIFF	267205	1	1550,551,555, 1552,553,557 1556,558,	
6 HINTERRADHAND-BREMSHEBEL	267950	1	1550,551,555, 1552,553,557, 1556,558,	
7 BREMSLICHT-SCHALTER	126899	1	1550,551,555, 1552,553,557 1556,558,	
8 HINTERRADBREMS-GRIF KPL.	267252	1	1550,551,555, 1552,553,557, 1556,558,	
9 LENKER	268100	1	1550,551,555, 1556,	IA: MIT ABB. 2-7
9 LENKER	272398	1	1550,551,555, 1552,553,557, 1556,558,	IB: AB FG-NR.: NSLIT 125945
10 MUTTER	015252	1	1550,551,555, 1552,553,557 1556,558,	
11 FEDERRING	016410	1	1550,551,552, 1553,	
11 FEDERRING	012535	1	1555,556,557, 1558,	
12 U-SCHEIBE	016626	1	1550,551,555, 1552,553,557 1556,558,	
13 SCHRAUBE	015542	1	1550,551,555, 1552,553,557 1556,558,	

I TAFEL 35

GAS- / VERGASER- / OELPUMPENZUG

SPALTE 11A

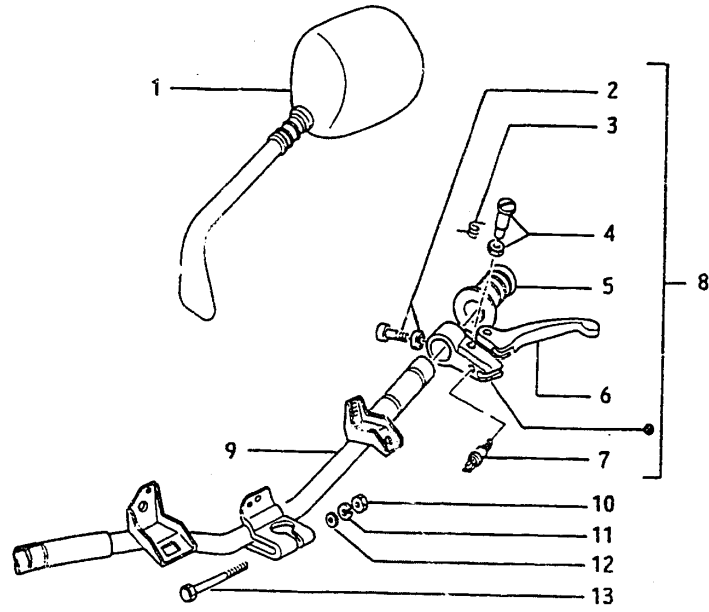
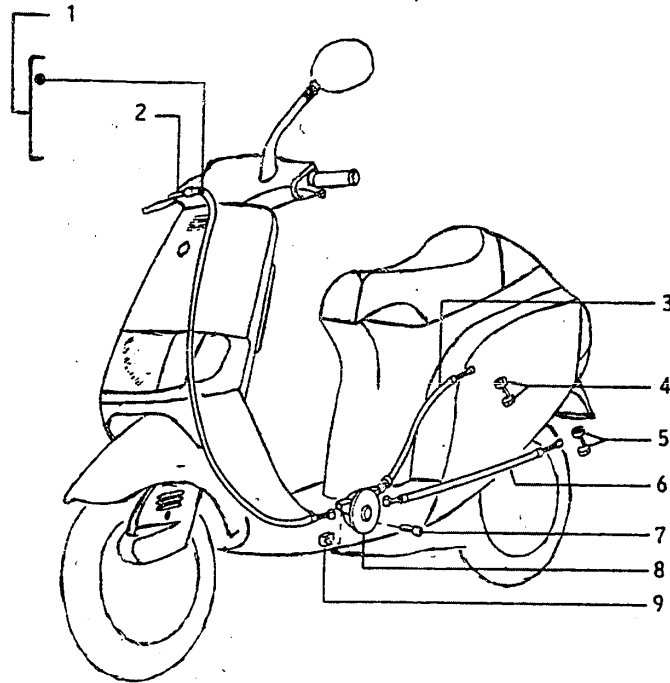

I ABB. BENENNUNG

I ERSATZTEIL I ST

IKENNZIFFER

IBEMERKUNGEN

I ABB. BENENNUNG	I ERSATZTEIL I ST	IKENNZIFFER	IBEMERKUNGEN
I 1 GASZUG KPL.	I 267981 I	I 1 1550,555,	IA: MIT ABB. 2
I 1 GASZUG KPL.	I 268813 I	I 1 1550,551,555,	IB: AB MAERZ 93
I 2 GASZUGSEIL	I 267982 I	I 1 1550,551,555,	
I 3 VERGASERZUG	I 267017 I	I 1 1550,	
I 3 VERGASERZUG	I 268811 I	I 1 1550,551,552,	
I 3 VERGASERZUG	I 268409 I	I 1 1555,	
I 3 VERGASERZUG	I 270305 I	I 1 1555,556,557,	
I 4 EINSTELLSCHRAUBE	I 498338 I	I 1 1530,551,555,	
I 5 EINSTELLSCHRAUBE	I 498339 I	I 1 1550,551,555,	
I 6 OELPUMPENZUG	I 267018 I	I 1 1550,	
I 6 OELPUMPENZUG	I 268812 I	I 1 1550,551,552,	
I 6 OELPUMPENZUG	I 268410 I	I 1 1555,	
I 6 OELPUMPENZUG	I 270306 I	I 1 1555,556,557,	
I 7 SCHRAUBE	I 031088 I	I 1 1550,551,555,	
I 8 UMLENKROLLE	I 267916 I	I 1 1550,551,555,	
I 9 FEDERKLAMMER	I 254485 I	I 1 1550,551,555,	
I KAPPE F. GASSEIL	I 289903 I	I 1 1550,551,555,	

I TAFEL 37

1 -

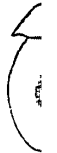

I TAFEL 36

BREMSZUG / TACHOWELLE

SPALTE 11B

I ABB. BENENNUNG

I ERSATZTEIL I ST

IKENNZIFFER

IBEMERKUNGEN

I TAFEL 38

S

ITAFEL 36 BREMSZUG / TACHOWELLE

SPALTE 11B



ABB. BENENNUNG	ERSATZTEIL	ST	KENNZIFFER	BEMERKUNGEN
1 TACHOWELLE KPL.	266848	1	1550,551,555, 1552,553,557	IA: MIT ABB. 2
2 TACHOSEELE	267750	1	1556,558, 1550,551,555, 1552,553,557	
3 VORDERRADBREMSZUG	268195	1	1556,558, 1550,551,555, 1552,553,557	
4 NIPPEL	179640	1	1550,551,555, 1552,553,557, 1556,558	
5 BREMSEINSTELL- SCHRAUBE	270311	1	1550,551,555, 1552,553,557, 1556,558	
6 FEDER	268172	1	1550,551,555, 1552,553,557, 1556,558	
7 PLAETTCHEN	287027	1	1550,551,555, 1552,553,557, 1556,558	
8 FEDER	191002	1	1550,551,555, 1552,553,557, 1556,558	
9 NIPPEL	266033	1	1550,551,552, 1553	
9 NIPPEL	179640	1	1555,556,557, 1558	
10 BREMSEINSTELL- SCHRAUBE	270310	1	1550,551,555, 1552,553,557, 1556,558	
11 HINTERRADBREMSZUG	266213	1	1550,551,555, 1552,553,557, 1556,558	
O-RING F. TACHO- WELLE	006716	1	1550,551,555, 1552,553,557, 1556,558	

ITAFEL 38

2 -
3 -
4 -

ITAFEL 39

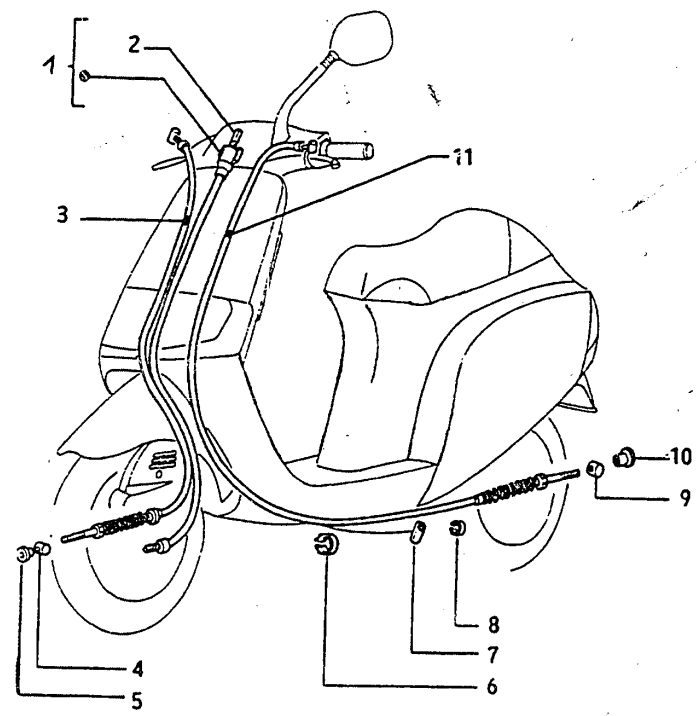
TAFEL 37	ELEKTRISCHE ANLAGE	SPALTE 12A	IABB. BENENNUNG	I ERSATZTEIL	I ST IKENNZIFFER	I BEMERKUNGEN	TAFEL 42	R.
			1 KABELBAUM	291281	1 1550,551,555, 1556,			
			1 KABELBAUM	292623	1 1550,551,555, 1552,553,557, 1556,558,	IF: AB APRIL 93		
			2 ZUENDKABEL	080341	1 1550,551,555, 1552,553,557, 1556,558,	IA: METERWARE		
			3 ELEKTRONIK-ZENTRALE	252537	1 1550,555,			
			3 ELEKTRONIK-ZENTRALE	292194	1 1550,551,555, 1552,553,557, 1556,558,	ID: AB FG-NR.: NSLIT 107660		
			4 MUTTER	020105	2 1550,551,555, 1552,553,557, 1556,558,			
			5 FEDERRING	016405	2 1550,551,555, 1552,553,557, 1556,558,			
			6 U-SCHEIBE	016686	2 1550,551,555, 1552,553,557, 1556,558,			
			7 ISOLIERKAPPE	231571	1 1550,551,555, 1552,553,557, 1556,558,			
			8 ISOLIERKAPPE	216976	1 1550,			
			8 ISOLIERKAPPE	255256	1 1550,551,555, 1552,553,557, 1556,558,	IB: FUER MODELL 550: AB JUNI 1991.		
			9 ISOLIERKAPPE	288632	1 1550,555,			
			9 ISOLIERKAPPE	292005	1 1550,551,555, 1552,553,557, 1556,558,	IE: AB FG-NR.: NSLIT 123283		
			10 ELEKTRON. REGLER	185824	1 1550,555,			
			11 ZUENDKERZEN-STECKER	255983	1 1550,555,			
			11 ZUENDKERZEN-STECKER	291894	1 1550,551,555, 1552,553,557, 1556,558,			
			12 ISOLIERKAPPE	155753	1 1550,551,552, 1553,			
			12 ISOLIERKAPPE	071671	1 1555,556,557, 1558,			
			13 SCHRAUBE	015558	2 1550,551,555, 1552,553,557, 1556,558,			
			14 FEDERRING	016406	2 1550,551,555, 1552,553,557, 1556,558,			
			15 U-SCHEIBE	003056	2 1550,551,555, 1552,553,557, 1556,558,			

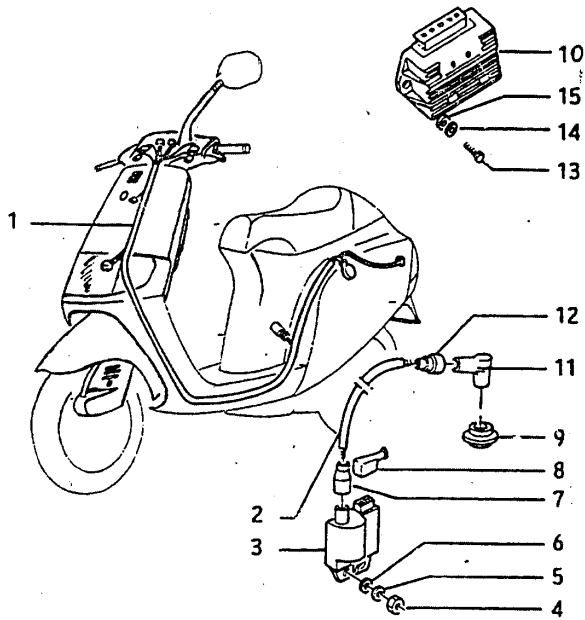

I TAFEL 38

SCHEINWERFER

SPALTE 12B

I ABB. BENENNUNG

I ERSATZTEIL

I ST IKENNZIFFER

I BEMERKUNGEN

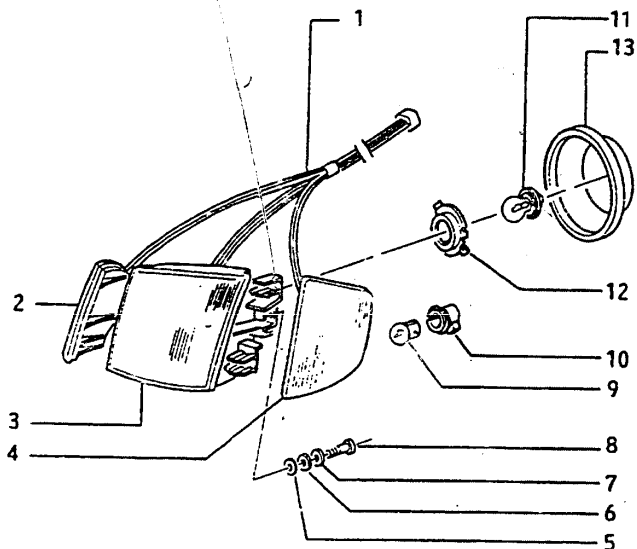

1	KABELAST FUER SCHEINWERFER UND BLINKLEUCHTEN	291284	1	1550,551,555, 1552,553,557, 1556,558,
---	--	--------	---	---------------------------------------

2	BLINKLEUCHE RE	290947	1	1550,551,555, 1552,553,557, 1556,558,
---	----------------	--------	---	---------------------------------------

3	SCHEINWERFER	290965	1	1550,551,555, 1552,553,557, 1556,558,
---	--------------	--------	---	---------------------------------------

4	BLINKLEUCHE LI	290946	1	1550,551,555, 1552,553,557, 1556,558,
---	----------------	--------	---	---------------------------------------

5	U-SCHEIBE	003056	2	1550,551,555, 1552,553,557, 1556,558,
---	-----------	--------	---	---------------------------------------

6	U-SCHEIBE	003055	2	1550,551,555, 1552,553,557, 1556,558,
---	-----------	--------	---	---------------------------------------

7	FEDERRING	016406	2	1550,551,555, 1552,553,557, 1556,558,
---	-----------	--------	---	---------------------------------------

8	SCHRAUBE	258248	2	1550,551,552, 1553,
---	----------	--------	---	---------------------

8	SCHRAUBE	257403	2	1555,556,557, 1558,
---	----------	--------	---	---------------------

9	LAMPE 12V-10W	181746	2	1550,551,555, 1552,553,557, 1556,558,
---	---------------	--------	---	---------------------------------------

10	LAMPENFASSUNG	250521	2	1550,551,555, 1552,553,557, 1556,558,
----	---------------	--------	---	---------------------------------------

11	LAMPE 12V-35/35W	219528	1	1550,551,555, 1552,553,557, 1556,558,
----	------------------	--------	---	---------------------------------------

12	LAMPENFASSUNG	290966	1	1550,551,555, 1552,553,557, 1556,558,
----	---------------	--------	---	---------------------------------------

13	SCHEINWERFER-VERSCHLUSSKAPPE	290949	1	1550,551,555, 1552,553,557, 1556,558,
----	------------------------------	--------	---	---------------------------------------

I TAFEL 39

RUECKLEUCHE / BLINKLEUCHTEN

SPALTE 12C

I ABB. BENENNUNG

I ERSATZTEIL

I ST IKENNZIFFER

I BEMERKUNGEN

TAFEL 39	RUECKLEUCHTE / BLINKLEUCHTEN	SPALTE 12C	I ABB. BENENNUNG	I ERSATZTEIL	I ST	I KENNZIFFER	I BEMERKUNGEN
			1 RUECKLEUCHTE-/ BLINKLEUCHTEN- EINSATZ	290943	1	1550,551,555, 1552,553,557, 1556,558,	
			2 LAMPE 12V-10W	181746	1	1550,551,555, 1552,553,557, 1556,558,	
			3 KABELAST	291286	1	1550,551,555, 1552,553,557, 1556,558,	
			4 SCHRAUBE	257404	1	1530,	
			4 SCHRAUBE	031116	1	1550,551,555, 1552,553,557, 1556,558,	IA: FUER MODELL 550: AB MAERZI 1931.
			5 SCHEIBE	006032	1	1550,551,555, 1552,553,557, 1556,558,	
			6 HECKVERKLEIDUNG MIT AUFNAHME FUER I LEUCHTENEINSATZ	259167	1	1550,551,555, 1556,	
			6 HECKVERKLEIDUNG WIE VOR, GRAUBLAU	296534	1	1552,553,557, 1558,	IB: AB APRIL 94
			6 HECKVERKLEIDUNG WIE VOR, GRAU	296563	1	1552,553,557, 1558,	
			7 U-SCHEIBE	003056	2	1550,551,555, 1552,553,557, 1556,558,	
			8 SCHRAUBE	290833	2	1550,551,555, 1552,553,557, 1556,558,	
			9 LAMPE 12V-5/21W	129953	1	1550,551,555, 1552,553,557, 1556,558,	
			10 LAMPE 12V-10W	181746	1	1550,551,555, 1552,553,557, 1556,558,	
			11 BLINKLEUCHTEN- KAPPE HINTEN LI	290941	1	1550,551,555, 1552,553,557, 1556,558,	
			12 BLINKLEUCHTEN- KAPPE HINTEN RE	290942	1	1550,551,555, 1552,553,557, 1556,558,	
			13 SCHRAUBE	290944	2	1550,551,555, 1552,553,557, 1556,558,	
			14 RUECKLEUCHTEN- KAPPE	290940	1	1550,551,555, 1552,553,557, 1556,558,	

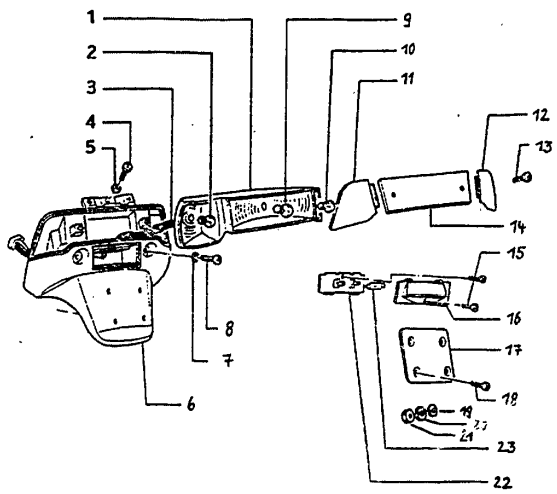

TAFEL 39	RUECKLEUCHTE / BLINKLEUCHTEN	SPALTE 12D	I ABB. BENENNUNG	I ERSATZTEIL	I ST	I KENNZIFFER	I BEMERKUNGEN
----------	------------------------------	------------	------------------	--------------	------	--------------	---------------

TAFEL 39	RUECKLEUCHE / BLINKLEUCHTEN	SPALTE 12D	I ABB. BENENNUNG	I ERSATZTEIL	I ST	I KENNZIFFER	I BEMERKUNGEN
			15 SCHRAUBE FUER KENNZEICHEN-LEUCHTENHALTER	015859	2	1550,551,555, 1552,553,557, 1556,558,	
			16 KENNZEICHEN-LEUCHTENHALTER	290801	1	1550,551,555, 1556,	
			16 KENNZEICHEN-LEUCHTENHALTER GRAUBLAU	296535	1	1552,553,557, 1558,	18: AB APRIL 94
			16 KENNZEICHEN-LEUCHTENHALTER GRAU	296564	1	1552,553,557, 1558,	
			17 KENNZEICHEN-TRAEGER	197999	1	1550,551,552, 1553,	
			17 KENNZEICHEN-TRAEGER	291208	1	1555,556,557, 1558,	
			18 SCHRAUBE F.KZ-TR.	015585	4	1550,551,552, 1553,	
			18 SCHRAUBE F.KZ-TR.	018623	4	1555,556,557, 1558,	
			19 U-SCHIEBE F.KZ-TR	003055	4	1550,551,552, 1553,	
			20 FEDERRING F.KZ-TR	016405	4	1550,551,552, 1553,	
			21 MUTTER F. KZ-TR.	020105	4	1550,551,552, 1553,	
			22 LAMPENHALTER	290802	1	1550,551,555, 1552,553,557 1556,558,	
			23 LAMPE 12V-5W	071633	1	1550,551,555, 1552,553,557 1556,558,	

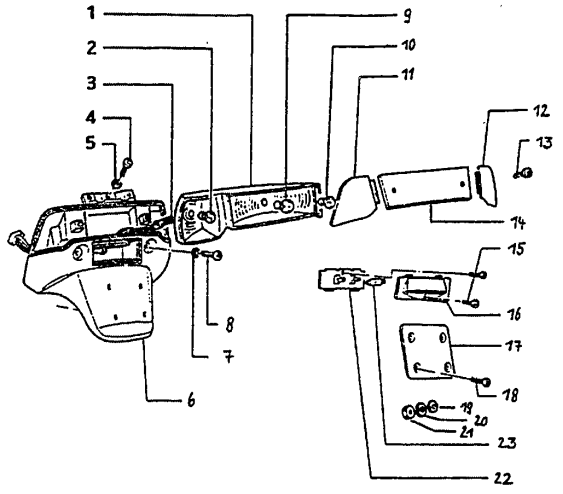

TAFEL 40	SCHALTEREINRICHTUNG AM LENKER	SPALTE 12E	I ABB. BENENNUNG	I ERSATZTEIL	I ST	I KENNZIFFER	I BEMERKUNGEN
----------	-------------------------------	------------	------------------	--------------	------	--------------	---------------

TAFEL 40 SCHALTEREINRICHTUNG AM LENKER SPALTE 12E		ABB. BENENNUNG	ERSATZTEIL	ST	IKENNZIFFER	IBEMERKUNGEN
	1	1 LICHTSCHALTER	290971	1	1550,551,555, 1552,553,557 1556,558,	
	2	2 HUPENSCHALTER	290679	1	1550,551,555, 1552,553,557 1556,558,	
	3	3 HUPE	290994	1	1550,551,555, 1552,553,557 1556,558,	
	4	4 FEDERING	016406	1	1550,551,555, 1552,553,557 1556,558,	
	5	5 SCHRAUBE	031086	1	1550,551,555, 1552,553,557 1556,558,	
	6	6 SCHLOSSSATZ, BE- STEHEND AUS KOMBINIERTEM ZUEND-/LENKSCHL. U. SITZBANKSCHL. AUS TAFEL 24	179292	1	1550,551,555, 1552,553,557, 1556,558,	IA: MIT ABB. 7
	7	7 SCHLUESSEL	257710	2	1550,551,555, 1552,553,557 1556,558,	IB: BEI BE-
	8	8 SCHLOSSKOERPER	416016	1	1550,555, 1	STELLUNG SCHLUESSELNR. ANGEBEN.
	8	8 SCHLOSSKOERPER	248240	1	1550,551,555, 1552,553,557 1556,558,	IC: AB FG-NR.:
	9	9 U-SCHEIBE	253093	1	1550,551,555, 1552,553,557 1556,558,	NSLIT 91225
	10	10 DRUCKKNOPF	256910	1	1550,551,555, 1552,553,557 1556,558,	
	11	11 FEDER	253937	1	1550,551,555, 1552,553,557 1556,558,	
	12	12 ZUENDSCHALTER	291059	1	1550,551,555, 1552,553,557 1556,558,	
	13	13 ANLASSERSCHALTER	290680	1	1550,551,555, 1552,553,557 1556,558,	
	14	14 BLINKERSCHALTER	290682	1	1550,551,555, 1552,553,557 1556,558,	
15	15 LICHTUMSCHALTER F. FERN-/ABBLEND- LICHT	290687	1	1550,551,555, 1552,553,557, 1556,558,		

TAFEL 41 BATTERIE, FERNSCHALTER F. ANLASSER SPALTE 12F		ABB. BENENNUNG	ERSATZTEIL	ST	IKENNZIFFER	IBEMERKUNGEN
--	--	----------------	------------	----	-------------	--------------

TAFEL 41 BATTERIE, FERNSCHALTER F. ANLASSER SPALTE 12F



ABB. BENENNUNG	ERSATZTEIL	ST	IKENNZIFFER	BEMERKUNGEN
1 KABELAST FUER BATTERIE	291071	1	1550,551,555, 1552,553,557, 1556,558,	
2 BATTERIE	234390	1	1550,551,552, 1553,	
2 BATTERIE	217153	1	1555,556,557, 1558,	
3 FERNSCHALTER FUER ANLASSER	290042	1	1550,551,555, 1552,553,557, 1556,558,	
4 SCHRAUBE	015558	1	1550,551,555, 1552,553,557 1556,558,	
5 U-SCHEIBE	003056	1	1550,551,555, 1552,553,557 1556,558,	
6 FEDERRING	016406	1	1550,551,555, 1552,553,557 1556,558,	
7 BLINKGEBER	291016	1	1550,551,555, 1552,553,557 1556,558,	
8 ELAST. HALTERUNG	291017	1	1550,551,555, 1552,553,557 1556,558,	
9 DIODE	217702	1	1550,551,555, 1552,553,557 1556,558,	
10 HALTER	290405	1	1550,551,555, 1552,553,557 1556,558,	
11 MUTTER	020003	1	1550,551,555, 1552,553,557 1556,558,	
12 FEDERRING	006963	1	1550,551,555, 1552,553,557 1556,558,	
13 SCHRAUBE	014404	1	1550,551,555, 1552,553,557 1556,558,	
14 ABSCHMELZ-SICHERUNG	252945	1	1550,551,555, 1552,553,557, 1556,558,	
15 SICHERUNGSHALTER	290402	1	1550,551,555, 1552,553,557, 1556,558,	IA: MIT ABB. 14



ABB. BENENNUNG	ERSATZTEIL	ST	IKENNZIFFER	BEMERKUNGEN
1 LUFTVENTIL	266434	2	1550,551,555, 1552,553,557, 1556,558,	
2 REIFEN	267503	2	1550,555,	
2 REIFEN, VORDERRADI	269796	1	1550,551,555, 1552,553,557, 1556,558,	IB: AB FG-NR.: NSLIT 78454 NSB1T 16624
2 REIFEN, HINTERRADI	269257	1	1550,551,555, 1552,553,557, 1556,558,	
3 LAGER	266843	2	1550,551,555, 1552,553,557, 1556,558,	
4 DISTANZROHR	266837	1	1550,551,555, 1552,553,557, 1556,558,	
5 VORDERRADFELGE KPI	267544	1	1550,555,	IA: MIT ABB. 3+4
5 VORDERRADFELGE KPI	269263	1	1550,551,555, 1552,553,557, 1556,558,	
6 HINTERRADFELGE	267547	1	1550,555,	
6 HINTERRADFELGE	269256	1	1550,551,555, 1552,553,557, 1556,558,	
7 SCHUTZKAPPE	267001	1	1550,551,555, 1552,553,557, 1556,558,	
8 WERKZEUGSATZ KPL.	249269	1	1550,551,555, 1552,553,557, 1556,558,	



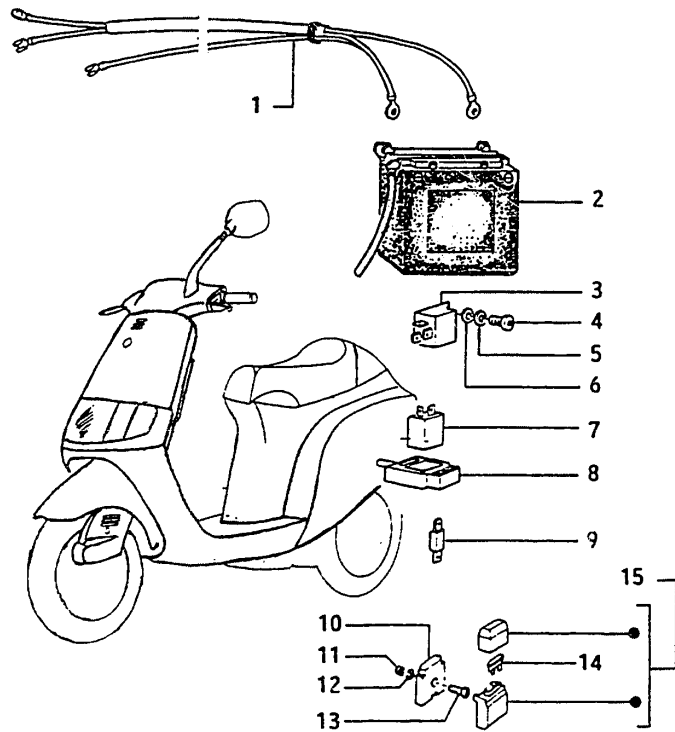

1	ABZIEHER F. LAGER	19.1.14499	1	1550,551,555, 1552,553,557, 1556,558,
2	GERAET ZUM AUSBAU DES OBEREN LAUF- RINGES DES UNT. STEUERROHRLAGERS	19.1.20004	1	1550,551,555, 1552,553,557, 1556,558,
3	WERKZEUG ZUR REVISION DER VORDERRADAUF- HAENGUNG	19.1.20021	1	1550,551,555, 1552,553,557, 1556,558,
4	SCHLAGDORNE FUER NADELHUELSEN	19.1.20037	1	1550,551,555, 1552,553,557, 1556,558,
5	SCHLUESSEL FUER OBERE NUTMUTTER DES STEUERROHRES	19.1.20055	1	1550,551,555, 1552,553,557, 1556,558,
6	ABZIEHER FUER LICHTMASCHINE	19.1.20162	1	1550,551,555, 1552,553,557, 1556,558,
7	HALTEPLATTE FUER KURBELWELLEN- HAUSE	19.1.20163	1	1550,551,555, 1552,553,557, 1556,558,
8	FUEHRUNG F. MON- TAGE DER KEIL- RIEMENSCHLEIBE	19.1.20164	1	1550,551,555, 1552,553,557, 1556,558,
9	HALTERUNG FUER STARTERZAHNKRANZ	19.1.20165	1	1550,551,555, 1552,553,557, 1556,558,
10	WERKZEUG FUER KOLBENMONTAGE	19.1.20166	1	1550,551,555, 1552,553,557, 1556,558,
11	WERKZEUG FUER STEUERROHRLAGER	19.1.21330	1	1550,551,555, 1552,553,557, 1556,558,
12	ABZIEHER	19.1.21467	1	1550,551,555, 1552,553,557, 1556,558,
13	MOTORHALTERUNG	19.1.25095	1	1550,551,555, 1552,553,557, 1556,558,
14	HALTER	19.1.35507	1	1550,551,555, 1552,553,557, 1556,558,

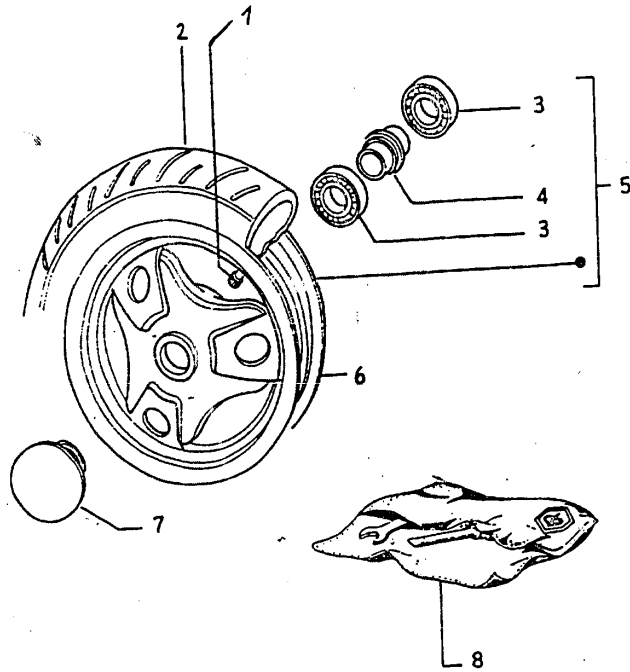
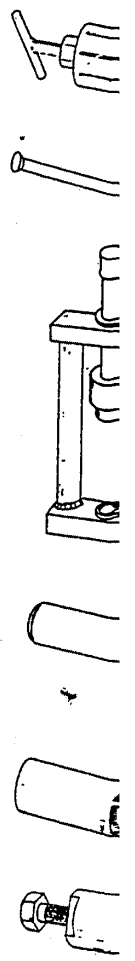
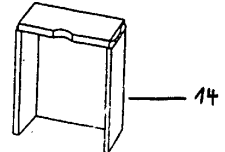
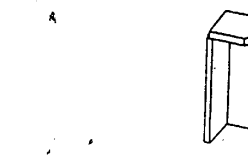
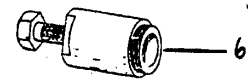
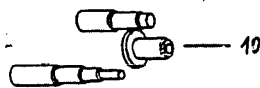
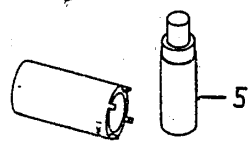
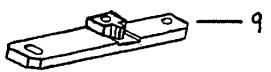
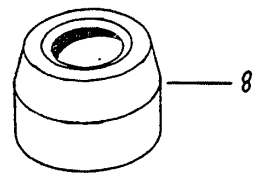
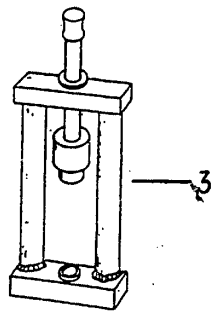
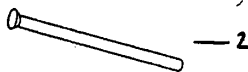
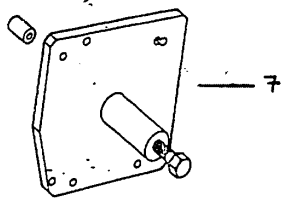
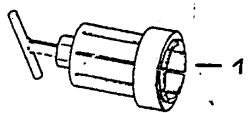
ERSATZTEIL - NUMMERN - VERZEICHNIS

TEILE-NR.	SALTE	TEILE-NR.	SALTE	TEILE-NR.	SALTE	TEILE-NR.	SALTE	TEILE-NR.	SALTE
000267	3H	016405	8B 12A 12D	123389	10C	217702	12F	257369	4D
000397	3L	016406	3J 4E 7D	123391	10C	218677	6A	257370	4D
003054	4E		7F 7F 8A	123394	10C 10D	219379	6B	257403	5C 5E 6B
003055	12B 12D	016408	4E 7C 9A	126899	10C 10D	219397	8D		6B 7D 12B
003056	5B 5C 5D		9B	129953	12C	219528	12B	257404	5C 5E 6A
	7D 8A 12A	016410	9A 10D	137679	6C	224309	3F		6D 7A 7F
003058	4E 5A 7B	016626	10D	138345	3L	224368	5A	257405	5E
003060	5A 9B	016686	12A	152608	4C	225743	9A	257415	5C
003751	8A	018584	4E	153024	8A	225748	9A	257513	6D
006032	12C	018623	12D	153025	8A	229935	10C	257532	7A
006125	4D	019264	8A	154873	2A	231571	12A	257533	7A
006416	3J	020003	12F	155753	12A	232108	5A 9B	257536	6D
006419	3F	020006	2B 2E 4E	159347	3F	234390	12F	257537	6D
006647	3G	020008	2B 5A	164634	10A	239382	2B	257538	6A
006716	11B	020105	3A 12A 12D	174088	9A	239391	2C	257613	5D 5E
006731	8B	020106	3I 7D 8A	177072	10C	239397	2D	257614	5E
006963	12F		8D	177408	8B	239403	2D	257616	5D
006964	3D	020108	7C 9A	177432	8B	239404	2D	257617	5D
006965	3H	021108	9B	177436	8B	239455	2D	257710	12E
006975	3A 3K	021110	3H	177445	8B	239848	3F	257712	4E
008108	7B	021210	9A	177451	8B	240006	4B	257803	5D
008375	2E	030054	7D	177521	8B	241126	4B	257817	6B
008455	7B	030074	9A	177609	8D	245255	3G	257832	7A
008714	3F	031056	8B	177671	8B	247654	4B	257833	7A
008808	7A	031086	7E 12E	178149	9B	248240	12E	257836	5D
010028	4B	031087	7D	178150	9B	249269	13A	257841	4A
011109	8A	031088	7F 7F 11A	179292	7B 12E	250521	12B	257867	7A
012533	2E 4D 7D	031089	4E	179575	6B 6B 8D	251875	7D	257897	7A
012535	10D	031091	3I	179640	11B 11B	252420	5D	257947	6D
012789	3F 8D	031092	7D	180859	7B	252537	12A	258160	6C
013769	4D 10A	031116	7B 12C	181746	12B 12C 12C	252832	6B	258161	6B
013777	7D	031119	9A	184142	5C 5D 6D	252945	12F	258235	7D
013861	4E	055986	8A		7A	253093	12E	258248	5C 6D 12B
013880	4D 7D 7D	055989	8A	185824	12A	253937	12E	258249	5C 5D 6D
014404	12F	056641	8A	191002	11B	254485	4D 5C 5D		6D 7A 10A
015123	3A	057894	9B	194011	6C		6C 6D 7A	258479	6A
015252	10D	071633	12D	194423	3F	255100	6C	258524	7A
015542	10D	071671	12A	194424	3F	255256	12A	258593	6D
015558	5B 6B 12A	077023	8A	195483	5A	255437	10A	258611	4E
	12F	077024	8A	196868	6A 6B	255983	12A	258728	4D
015585	3H 3H 3K	078307	2E	197572	6A	256074	6A 6C	258732	5D
	12D	080341	12A	197999	12D	256212	4E	258737	6D
015715	3A	085285	4C	198513	8B	256756	4E 4F	258775	5B
015759	8A	092667	8A	212128	10A	256910	12E	258776	5B
015792	4E	104296	3K 6A	216209	9A	257264	6B	258777	5B
015856	3A 3H 3K	109960	4A 4A	216233	9A	257272	7D	258778	5B
	3K	112145	2C	216234	9A	257301	6B 6B	258788	7A
015859	12D	113533	2B	216976	12A	257302	6B 6B	258828	6D
015947	3D	113903	4B	216983	3I	257303	6B	258981	4E
016404	4E 4F	119219	8B	217153	12F	257341	5D	258998	7B

ERSATZTEIL - NUMMERN - VERZEICHNIS

TEILE-NR.	SALTE	TEILE-NR.	SALTE	TEILE-NR.	SALTE	TEILE-NR.	SALTE	TEILE-NR.	SALTE
-----------	-------	-----------	-------	-----------	-------	-----------	-------	-----------	-------

ERSATZTEIL - NUMMERN - VERZEICHNIS

TEILE-NR.	SPALTE	TEILE-NR.	SPALTE	TEILE-NR.	SPALTE	TEILE-NR.	SPALTE	TEILE-NR.	SPALTE
258999	7B	267033	9B	268892	5A	286206	3A	288602	3F
259000	5B	267034	9B	269256	13A	286207	3A	288606	2E
259040	7A	267038	9B	269257	13A	286210	3I	288608	3F
259102	5D	267074	9A	269263	13A	286214	3I	288612	3K
259103	7A	267075	9A	269293	8D	286217	3I	288632	12A
259107	6B	267076	9A	269673	8A	286218	3I	288639	3F
259167	12C	267115	4D 10A	269796	13A	286219	3I	288649	3K
259209	5A	267124	10A	270300	10A	286271	3D	288673	3E
259274	4E	267144	10A	270301	10A	286328	3H	288694	3E
259307	4E	267145	10A	270303	10A	286359	2C	288696	3E
259310	4E	267158	10D	270305	11A	286534	2E	288737	3K
259403	6B	267169	10D	270306	11A	286808	3I	288741	4A
259442	6B	267189	8B	270310	11B	286810	2D	288748	2E
259625	3A 3I	267205	10D	270311	11B	286870	3D	288812	3F
259952	6A	267243	7F	270830	7F	286912	2C	288836	2E
259992	7C	267252	10D	271174	10C	286922	3F	288848	3B
265249	10C 10D	267421	6D	271181	10C	286927	3F	288862	4B
265808	7F 10B	267503	13A	271189	10C	286930	3F	288863	4B
266033	11B	267544	13A	271200	5A	286935	3A	288864	4B
266213	11B	267547	13A	271584	5A	286936	2E	288865	4C
266289	7B	267599	3L	271695	5A	287011	3B	288866	4B
266434	13A	267602	8D	272398	10D	287020	3I	288869	4B
266518	9A	267633	9B	272401	10C	287021	3K	288870	4B
266533	3L	267750	11B	272912	5A	287027	11B	288871	4C
266539	9A	267823	2B	272929	5A	287028	3B	288872	4C
266610	3L	267832	5A	272939	9B	287033	3C	288873	4C
266625	2B	267848	3A	273039	10A	287044	3D	288874	4C
266694	8D	267916	11A	273045	10A	287047	3F	288875	4B
266698	8B	267948	10D	273048	10A	287048	3F	288878	4C
266724	3L 8D	267949	10C	273071	10A	287056	3D	288879	4C
266725	3L 8D 8D	267950	10D	273075	8A	287057	3D	288880	4C
266774	5A	267981	11A	285007	3B	287061	3D	288881	4B
266775	5A	267982	11A	285017	3B 3C	287062	3D	288882	4B
266826	8C	268100	10D	285019	3B 3C	287073	3K	288883	4B
266829	8A	268158	9B	285358	3B 3B	287088	3B	288989	2D
266831	8B	268172	11B	285359	3B 3B	287090	3B	288990	2D
266835	8D	268195	11B	285394	3D	287090	3B	288991	2D
266837	13A	268205	5A	285396	3D	287106	3C	288992	2D
266840	8B	268207	5A	285430	3D	287223	2B	289000	2C
266841	8B	268300	7F	285434	3D	288041	3I	289030	2E
266843	13A	268409	11A	286158	3D	288245	2E 4E	289093	3K
266845	8D	268410	11A	286162	3K	288327	3K	289100	3D
266848	11B	268419	5A	286163	3K	288391	2B	289100	3D
266854	8B	268556	3L	286165	3K	288396	2D	289104	3D
266860	7D	268698	9B	286170	3D	288401	2E	289132	3F
266940	8B	268705	9B	286172	3I	288410	2E	289133	3G
267001	13A	268706	9B	286174	3I	288476	3F	289153	3A
267017	11A	268811	11A	286182	3B	288502	3F	289155	3A
267018	11A	268812	11A	286183	3B	288530	3B	289184	3B
267032	9B	268813	11A	286191	3B	288531	2E	289191	3K

ERSATZTEIL - NUMMERN - VERZEICHNIS

TEILE-NR.	SPALTE	TEILE-NR.	SPALTE	TEILE-NR.	SPALTE	TEILE-NR.	SPALTE	TEILE-NR.	SPALTE
-----------	--------	-----------	--------	-----------	--------	-----------	--------	-----------	--------

